

# UPDATE IN ANAESTHESIA



*A journal for anaesthetists in developing countries*

## WORLD ANAESTHESIA

### Editorial

The internet is an increasingly important source of information for anaesthetists. Many societies, journals and organisations provide websites, which often contain useful material for the clinician. Some of the mainline journals are prepared to give free access to healthcare workers in developing countries and either abstracts or full text articles can be downloaded. A list of useful anaesthesia related sites is given on page 48 and one of these, the Virtual Anaesthetic Machine is featured on page 30. We would be pleased to review more anaesthesia related sites, particularly of an educational nature. Readers should, however, be aware that it can be difficult to ensure the accuracy of all information provided via the internet.

Our own website [www.nda.ox.ac.uk/wfsa](http://www.nda.ox.ac.uk/wfsa) has seen a large increase in the number of people accessing it. In March 2002 we had an average of 114 visits daily, from 134 different countries. Recently both the Russian and French editions of Update have become available on-line (details below) and it is hoped to provide the Spanish version in the near future. All previous editions of Update and the Primary Trauma Care Manual are available on a free computer CD ROM (email: [pip.elphick@e-talc.org](mailto:pip.elphick@e-talc.org)) and on the web.

The demand for Update continues to increase both for the printed and electronic version. We hope that it continues to be of interest. Please send ideas for articles or topics to the editor, preferably by email. Whenever possible please access the electronic versions of Update (internet or CD ROM). The paper version is expensive to post overseas, and is produced for those anaesthetists without computer access. We are very grateful for the continuing support of the World Federation of Societies of Anesthesiologists in the production and distribution of Update in Anaesthesia.

Dr Iain Wilson

Editor - Update in Anaesthesia

Email: [iain.wilson5@virgin.net](mailto:iain.wilson5@virgin.net)

*Editor: Iain Wilson; Assistant Editors: Frank Walters, Rebecca Jacob, Barry Nicholls, Rob Law. Special thanks to Julia Munn and Charlie Collins for reviewing articles in this edition.*

No 14 2002

ISSN 1353-4882

### Contents: No 14

- Editorial
- Endocrine Physiology
- Book Review
- Anaesthesia for Patients with Cardiac Disease Undergoing Non-Cardiac Surgery
- ASA and CEPOD Scoring
- Clinical Use of Blood
- Levobupivacaine
- A Mobile Anaesthesia Service
- Anaesthesia for Cleft Lip and Palate Surgery
- Virtual Anaesthesia Machine
- Extracts from the Journals
- Letter to the Editor
- Case Report - Total Spinal Anaesthesia
- Self Assessment Section
- Answers to MCQ Questions
- Equipment - Vaporisers
- Obstetric Anaesthesia - Placental Abruption

### Contacts

Russian Edition:- Andrei Varvinski, Dept. of Anaesthesia, Torbay Hospital, Torquay, Devon, U.K.  
Email: [avarvinski@hotmail.com](mailto:avarvinski@hotmail.com)  
Website: [www.ua.arh.ru](http://www.ua.arh.ru)

Spanish Edition:- Oscar Gonzales, Rio Parana 445, Bo Felicidad - Lambare, Paraguay  
Email: [ojpgam@conexion.com.py](mailto:ojpgam@conexion.com.py)

French Edition:- Michel Pinaud, Service d'anaesthesia, Hotel Dieu, 44093 Nantes Cedex 1, France  
Website: [www.sfar.org/update/updatechapo.html](http://www.sfar.org/update/updatechapo.html)  
Mailing list email: [106147.2366@compuserve.com](mailto:106147.2366@compuserve.com)

Mandarin Edition:- Jing Zhao, Dept. of Anaesthesia, Peking Union Medical College Hospital, No. 1 Shuai Fu Yuan, Beijing 100730, Peoples Rep. of China

## ENDOCRINE PHYSIOLOGY

P.A. Farling, M.E. McBrien and D. Breslin\*. Department of Anaesthetics, Royal Victoria Hospital, Belfast, BT12 6BA \*Department of Anaesthetics, The Queen's University Belfast, BT9 7BL,  
E mail: [peter.farling@dnet.co.uk](mailto:peter.farling@dnet.co.uk)

Dr PA Farling MB, FFARCSI Consultant Anaesthetist  
Dr ME McBrien MB, FRCA Consultant Anaesthetist  
Dr D Breslin MB, FFARCSI Research Fellow

**Keywords: physiology, pituitary, thyroid, adrenal**

### Key to terms used

ADH	Antidiuretic Hormone	T <sub>3</sub>	Tri-iodothyronine
GH	Growth Hormone	T <sub>4</sub>	Thyroxine
GHRH	GH Releasing Hormone	GHRH	GH Releasing Inhibiting Hormone
LH	Luteinising Hormone	DDAVP	Desmopressin
TSH	Thyroid Stimulating Hormone	FSH	Follicular Stimulating Hormone
ACTH	Adrenocorticotrophic Hormone	CRH	Corticotrophic Releasing Hormone

## INTRODUCTION

The endocrine system acts through chemical messengers, hormones, to coordinate many bodily functions. It maintains the internal environment (homeostasis), controls the storage and utilisation of energy substrates, regulates growth and reproduction and, perhaps of greatest importance to anaesthetists, controls the body's responses to external stimuli, particularly stress.

This paper will concentrate on basic physiology of the principle endocrine glands, the pituitary, thyroid, and adrenal glands. Other endocrine glands include the pancreas, which has been dealt with in a recent paper on diabetes [*Clinical Management of Diabetes Mellitus during Anaesthesia and Surgery, Update in Anaesthesia 2000; 11: 65-73*], the hypothalamus, parathyroids and gonads. In addition, the liver, kidney, lungs, gastrointestinal tract, pineal gland and thymus produce many other hormone-like substances.

## THE PITUITARY GLAND.

### Anatomy

The pituitary gland lies within a dural covering in a depression of the skull base (sella turcica). On each side lies the cavernous sinus containing the carotid arteries and the III, IV and VI cranial nerves. The pituitary gland is attached to the hypothalamus in the floor of the third ventricle by the pituitary stalk (infundibulum), which passes through an aperture in the fold of dura mater forming the roof of the sella turcica (diaphragma sellae).

The pituitary gland is made up of 2 parts: **The posterior lobe** (neurohypophysis) is the expanded inferior end of the infundibulum, and is developed embryologically from the brain. The infundibulum contains axons of neurones from the supraoptic

and paraventricular nuclei of the hypothalamus which terminate on the surface of capillaries in the posterior lobe onto which they secrete the two posterior pituitary hormones, antidiuretic hormone (ADH) and oxytocin.

**The anterior lobe** (adenohypophysis) is much larger than the posterior lobe, and itself consists of 3 parts which partly surround the posterior lobe and the infundibulum (figure 1). The distal part forms most of the anterior lobe. The intermediate part, a thin sheet of non-functional glandular tissue and a narrow cleft separates the anterior lobe from the posterior lobe. The infundibular part of the anterior lobe is a narrow upward projection which partially encircles the infundibulum.

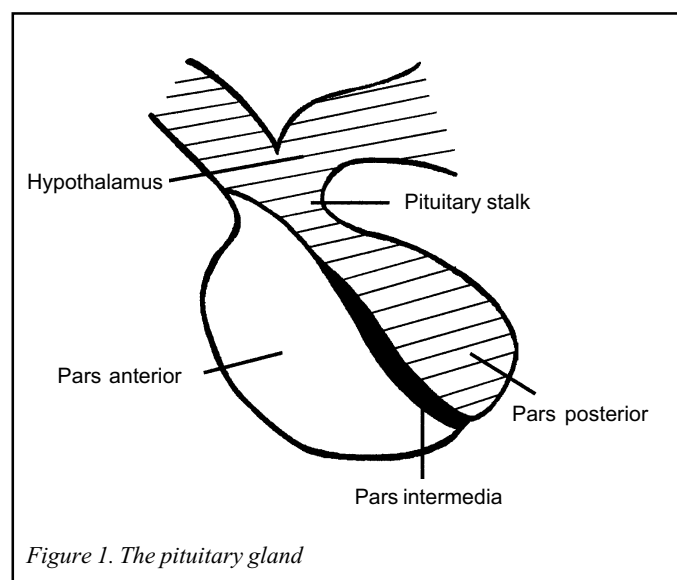

Figure 1. The pituitary gland

The blood supply to the pituitary gland is by twigs from the internal carotid and anterior cerebral arteries. The anterior lobe also receives venous blood from the hypothalamus via the **hypothalamo-hypophyseal portal system** of veins (figure 2), which transmits releasing factors to the pituitary from the lower tip of the hypothalamus. The veins of the pituitary drain into the cavernous sinuses.

Human anterior pituitary cells have traditionally been classified according to their staining characteristics into chromophobes, acidophils or basophils. With more modern techniques of immunohistochemistry and electron microscopy, it is now possible to distinguish 5 cell types: somatotropes, which secrete growth hormone (GH); lactotropes, which secrete prolactin; thyrotropes, which secrete thyroid stimulating hormone (TSH); gonadotropes, which secrete luteinizing hormone (LH) and follicle-stimulating hormone (FSH); and corticotropes, which secrete adreno-corticotrophic hormone (ACTH). They control a wide range of functions (figure 3). There are also functionally inert cells within the gland known as null cells.

**Control of pituitary secretion by the hypothalamus**

Almost all hormone secretion by the pituitary is controlled by either hormonal or nervous signals from the hypothalamus. The hypothalamus receives signals from almost all possible sources in the nervous system, and is itself under **negative feedback** control (figure 4) from the hormones regulated by the pituitary gland. This means that when there is a low level of hormone in the blood supplying the hypothalamus, it produces the appropriate releasing hormone or factor which stimulates the release of the hormone by the pituitary and this in turn stimulates the target

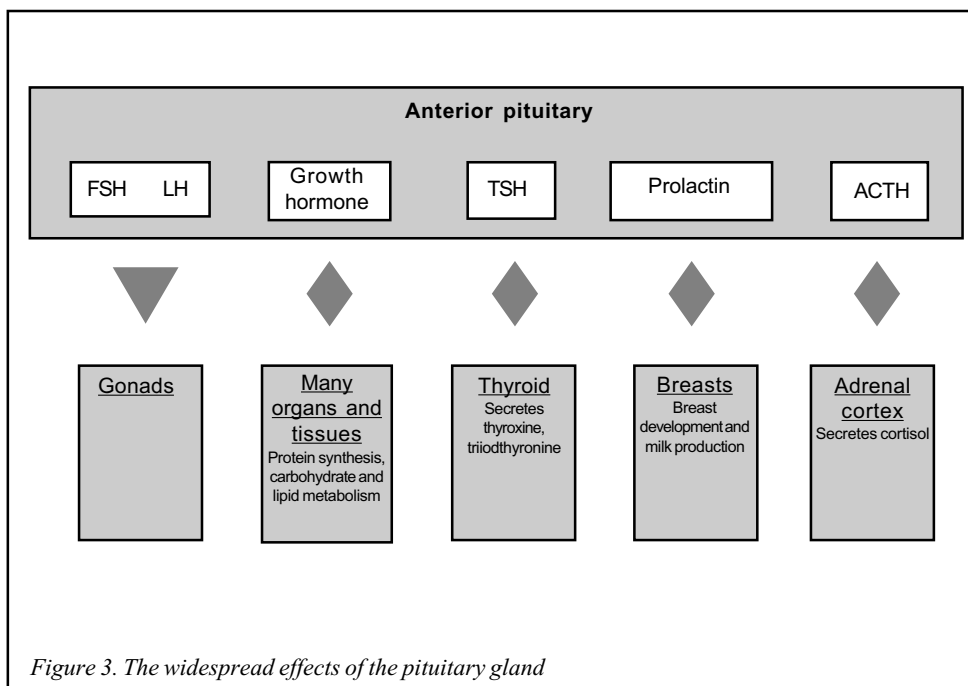

Figure 3. The widespread effects of the pituitary gland

gland to produce and release its hormone. As a result, the blood level of that hormone rises and inhibits the secretion of releasing hormone or factor by the hypothalamus.

Secretion from the posterior pituitary is controlled by nerve fibres arising in the hypothalamus which pass along nerve axons and terminate on blood vessels in that part of the gland.

Secretion from the anterior pituitary is controlled by hormones called **hypothalamic releasing** and **hypothalamic inhibitory hormones** (or factors) carried from the hypothalamus to that part of the gland by the hypothalamo-hypophyseal portal system. These hormones act on the glandular cells of the anterior pituitary to regulate their secretion.

**Hormones of the anterior pituitary gland**

**Growth Hormone**

**Effects**

1. Promotes the growth of bone, cartilage and soft tissue via the effects of insulin-like growth factor, IGF-1, (formerly known as somatomedin C) whose production is increased in the liver, kidney and other tissues in response to GH. If excess GH levels are present before fusion of the epiphyses occurs, **gigantism** occurs. After the epiphyses are closed, linear bone growth is no longer possible and excess GH leads to **acromegaly**.

There are a number of problems which are described briefly in Box 1.

- Increases the rate of protein synthesis in all cells of the body,
- Fat mobilisation by release of fatty acids from adipose tissue.
- Decreases the rate of glucose utilisation throughout the body due to diminished uptake of glucose by cells (i.e. it is counter-regulatory to insulin).
- Increased hepatic glucose output.

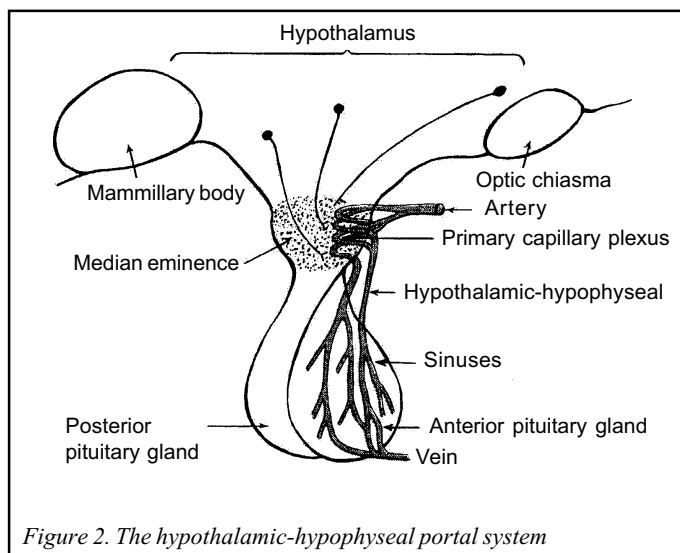
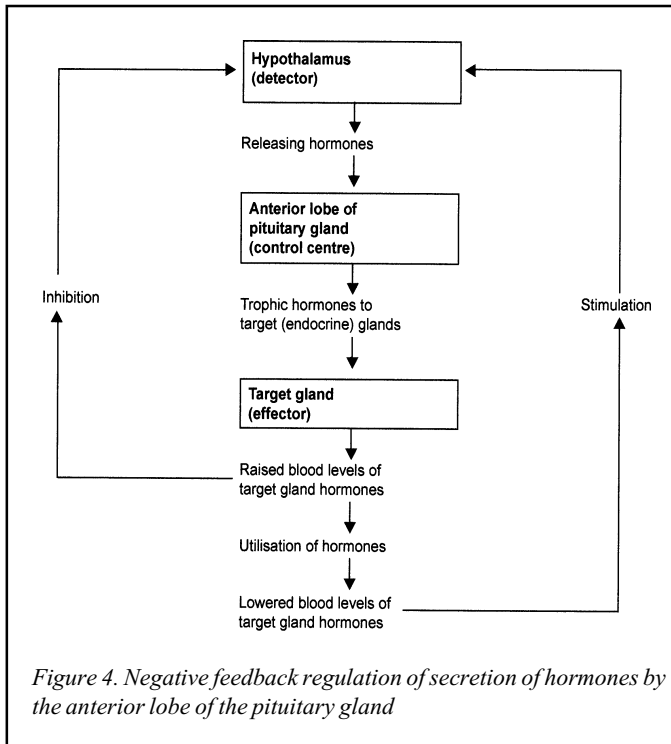

Figure 2. The hypothalamic-hypophyseal portal system



- Stimulates erythropoiesis.
- $\text{Na}^+$  and  $\text{K}^+$  excretion are reduced, while  $\text{Ca}^{++}$  absorption from the intestine is increased.

### Regulation

GH release from the anterior pituitary is under the control of the hypothalamus which secretes both a releasing hormone (growth hormone releasing hormone - GHRH) and an inhibitory hormone (growth hormone release-inhibiting hormone - GHRIH, or somatostatin) into the hypothalamo-hypophyseal portal system. GH and IGF-1 produce negative feedback effects on the hypothalamus and pituitary.

The stimuli that increase GH secretion fall into 3 general categories:

- Hypoglycaemia and fasting

- Increased amounts of certain amino acids in the plasma
- Stressful stimuli

Secretion of GH is reduced in response to increased concentrations of glucose, free fatty acids or cortisol in the plasma, and is also reduced during rapid eye movement sleep.

### Prolactin

#### Effects

Prolactin stimulates secretion of milk and has a direct effect on the breast immediately after parturition. Together with oestrogen and progesterone, prolactin initiates and maintains lactation.

#### Regulation

Secretion is tonically inhibited by the release of dopamine from the hypothalamus into the hypothalamo-hypophyseal portal system. Prolactin secretion can be intermittently increased by release of prolactin releasing hormone from the hypothalamus, such as when the baby suckles the breast.

### Thyroid Stimulating Hormone

#### Effects

Increases all the known activities of the thyroid glandular cells with increased production and secretion of thyroxine ( $\text{T}_4$ ) and triiodothyronine ( $\text{T}_3$ ) by the thyroid gland. Persistently elevated levels of TSH leads to hypertrophy of the thyroid with increased vascularity.

#### Regulation

TSH is produced and released from the anterior pituitary in response to thyrotropin releasing hormone released from the hypothalamus and carried to the pituitary via the hypothalamo-hypophyseal portal system. The hypothalamus can also inhibit TSH secretion via the effects of released somatostatin, in the same way that GH inhibition occurs. Free  $\text{T}_3$  and free  $\text{T}_4$  in the plasma exert a negative feedback effect on the hypothalamus and the pituitary to regulate the circulating levels of these hormones.

#### Box 1. Outline of anaesthetic problems associated with pituitary surgery for acromegaly

PROBLEM	MANAGEMENT
Overgrowth of the mandible, pharyngeal and laryngeal structures which may lead to difficult airway maintenance and intubation, and sleep apnoea with its complications	Careful pre-operative assessment. Consider tracheostomy under local anaesthesia or fiberoptic intubation
Cardiomyopathy with cardiac enlargement leading to congestive cardiac failure.	Cardiovascular assessment including ECG and chest X-ray. Medical management of hypertension prior to surgery.
Impaired glucose tolerance	Regular assessment of blood glucose. May require peri-operative insulin therapy

## Follicle stimulating hormone and Luteinizing hormone

### Effects

In men, FSH stimulates spermatogenesis by the Sertoli cells in the testis. In females, FSH causes early maturation of ovarian follicles.

In men, LH causes testosterone secretion by the Leydig cells in the testis. In females, LH is responsible for the final maturation of ovarian follicles and oestrogen secretion from them.

### Regulation

In males and females, LH and FSH production by the anterior pituitary is regulated by release of gonadotropin releasing hormone from the hypothalamus, which is carried to the pituitary in the hypothalamo-hypophyseal portal system. Feedback effects of testosterone, oestrogen and inhibin (produced in the testes and ovaries in response to FSH stimulation) on the hypothalamus and anterior pituitary regulates the levels of circulating LH and FSH.

## Adrenocorticotrophic hormone (ACTH)

ACTH is formed in the anterior pituitary by enzymatic cleavage of the prohormone pro-opiomelanocortin (POMC). This polypeptide is hydrolysed in the corticotropes to produce ACTH and  $\beta$ -lipotrophin ( $\beta$ -LPH). Some of the  $\beta$ -LPH is split to produce  $\beta$ -endorphin. The anterior pituitary secretes all 3 hormones - ACTH,  $\beta$ -LPH and  $\beta$ -endorphin. The physiologic role of  $\beta$ -LPH is unknown,  $\beta$ -endorphin is an endogenous opioid peptide.

### Effects

ACTH stimulates the production of cortisol (hydrocortisone) and androgens from the zona fasciculata and zona reticularis of the adrenal cortex. ACTH also acts on the cells in the zona glomerulosa to enable them to produce aldosterone in response to increased potassium ion concentration, elevated angiotensin levels or reduced total body sodium.

### Regulation

ACTH is secreted from the anterior pituitary in response to the production of corticotropin releasing hormone (CRH) from the hypothalamus, which is carried to the pituitary along the hypothalamo-hypophyseal portal system (figure 5). Excitation of the hypothalamus by any type of stress causes release of CRH, leading to secretion of ACTH from the anterior pituitary and subsequent release of cortisol from the adrenal cortex. There is direct feedback of the cortisol on the hypothalamus and anterior pituitary gland to stabilise the concentration of cortisol in the plasma.

## Hormones of the posterior pituitary gland

**Antidiuretic hormone** (ADH) is formed primarily in the supraoptic nuclei of the hypothalamus, while **oxytocin** is formed primarily in the paraventricular nuclei. Both hormones are transported from the hypothalamus to the posterior pituitary along axons in the infundibulum. Under resting conditions, large quantities of both hormones accumulate in the endings of the nerve fibres in the posterior pituitary. Excitatory nerve impulses in these fibres from their relevant nuclei cause release of the hormones with their subsequent absorption into adjacent capillaries.

## Antidiuretic hormone

### Effects

ADH promotes water retention by the kidneys by causing increased permeability of the collecting ducts to water, and its subsequent reabsorption from the tubular fluid (*Physiology of the Kidney, Update in Anaesthesia 1998; No 9:24-28*)

### Regulation

ADH is secreted in response to increased plasma osmolality, decreased extracellular fluid volume, pain and other stressed states, and in response to certain drugs including morphine and barbiturates. ADH secretion is inhibited by alcohol.

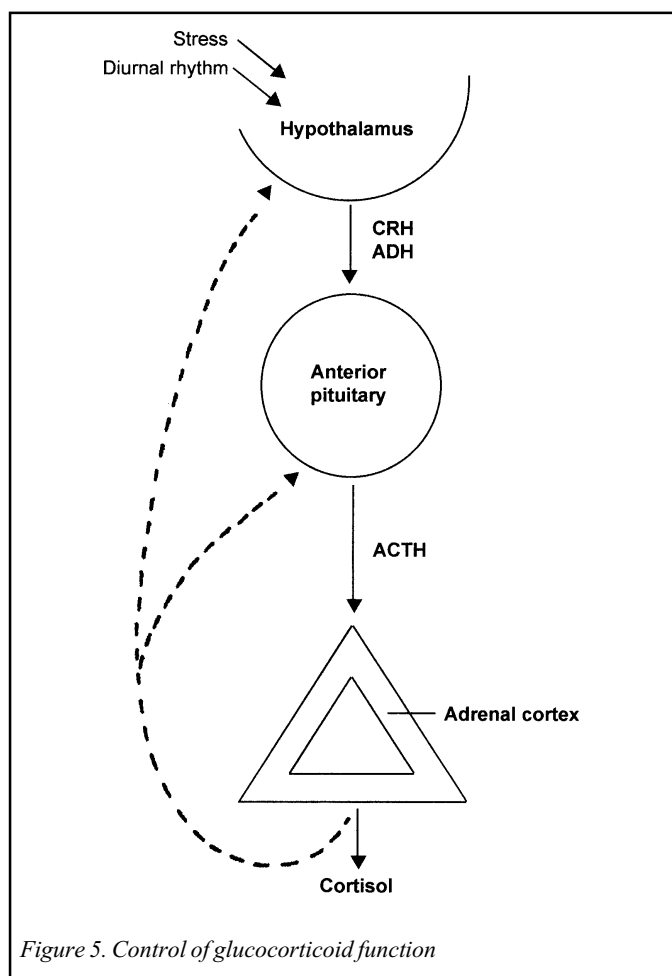

Figure 5. Control of glucocorticoid function

## Oxytocin

### Effects

- Contraction of the pregnant uterus.
- Contraction of the myoepithelial cells in the lactating breast, causing ejection of milk out of the alveoli into the milk ducts and thence out of the nipple.

### Regulation

Oxytocin secretion is increased during labour. Descent of the fetus down the birth canal initiates impulses in the afferent nerves that are relayed to the hypothalamus, causing release of oxytocin, which enhances labour. During suckling, touch receptors in the nipple of the breast transmit signals that terminate in the hypothalamus resulting in release of oxytocin to eject milk.

## THE THYROID GLAND.

### Embryology

The thyroid develops from the floor of the pharynx between the first and second pharyngeal pouches. It grows caudally as a tubular duct which eventually divides to form the isthmus and lobes. The thyroglossal duct extends from the foramen caecum, in the floor of the mouth, to the hyoid bone. The pyramidal lobe of the thyroid develops from the distal part of the duct. Aberrant thyroid tissue, eg a lingual thyroid, may develop from persistent remnants of the thyroglossal duct.

### Anatomy

Although the term *thyroid* is derived from the Greek word meaning shield, the gland is most commonly described as 'butterfly' shaped. The thyroid gland lies in the neck related to the anterior and lateral parts of the larynx and trachea. Anteriorly, its surface is convex; posteriorly, it is concave. It is composed of two lobes joined by an isthmus (figure 6). The isthmus lies across the trachea anteriorly just below the level of the cricoid cartilage. The lateral lobes extend along either side of the larynx as roughly conical projections reaching the level of the middle of the thyroid cartilage. Their upper extremities are known as the upper poles of the gland. Similarly, the lower extremities of the lateral lobes are known as the lower poles. The gland is brownish-red due to a rich blood supply.

### Histology

Each lobe is composed of spherical follicles surrounded by capillaries. The follicles comprise a single layer of epithelial cells forming a cavity that contains colloid where the thyroid hormones are stored as thyroglobulin. C-cells, which secrete calcitonin, are found outside the follicles.

### Synthesis and transport of thyroid hormones

Dietary iodide is concentrated by the thyroid gland and is oxidised, in the follicle cells, to iodine. The iodine is linked to tyrosine molecules in thyroglobulin, a large protein synthesised by the follicular cells into the cavity (figure 7). Iodinated tyrosine is coupled to form tri-iodothyronine ( $T_3$ ) and thyroxine ( $T_4$ ) which are then released into the circulation. Anti-thyroid drugs block

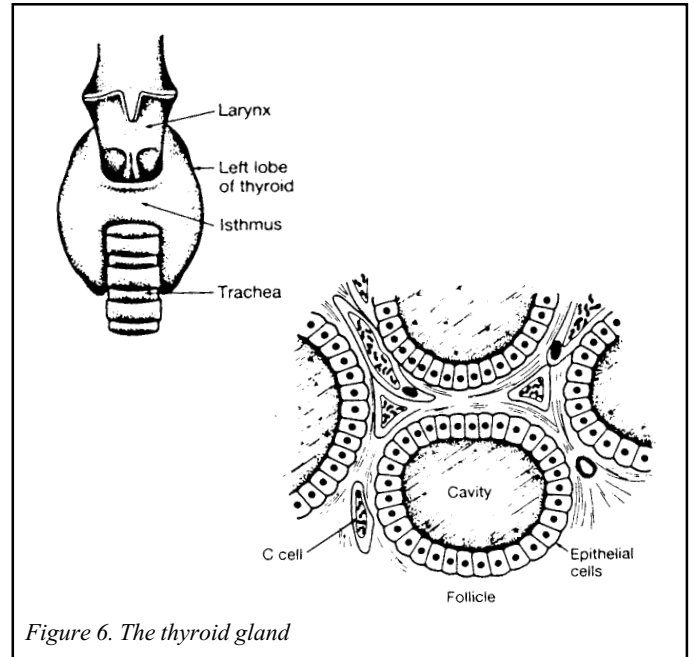

Figure 6. The thyroid gland

the synthesis of  $T_3$  and  $T_4$  by interfering with various steps of this process, for example, carbimazole blocks oxidation of iodide and iodination of tyrosine. All the steps in the synthesis of thyroid hormones are stimulated by thyroid stimulating hormone (TSH) secreted from the anterior pituitary gland.

$T_4$  is transported in the blood bound to plasma proteins, mainly  $T_4$ -binding globulin and albumin.  $T_3$  is less firmly bound to plasma proteins than  $T_4$ . Thyroid hormones are broken down in the liver and skeletal muscle and while much of the iodide is recycled some is lost in the urine and faeces. There is a need, therefore, for daily replacement of iodide in the diet. The half-life of  $T_4$  is 7 days and the half life of  $T_3$  is 1 day.

### Control of thyroid hormone secretion

There are two main factors controlling secretion of thyroid hormones. The first is autoregulation of the thyroid which adjusts for the range of iodide in the diet. The other is the secretion of TSH by the anterior pituitary. Other compounds may play a regulatory role such as neurotransmitters, prostaglandins and

#### Box 2. Hormonal problems occurring during pituitary surgery

1. Continue pre-operative hormone replacement therapy into the operative and post-operative period. Additional intravenous hydrocortisone (100mg IV) should be given at induction. Post-operative assessment by endocrinologist to determine duration of steroid replacement and need for thyroxine replacement. If medical hormonal assessment is unavailable, some authorities recommend the following regimen:-
  - 50mg hydrocortisone 12 hourly for 24 hours
  - 25mg hydrocortisone 12 hourly for 24 hours
  - 20mg hydrocortisone am 10 mg hydrocortisone pm
2. Post operative diabetes insipidus due to reduced production of ADH from the posterior pituitary following surgery
3. Careful assessment of post-operative fluid balance. Administration of DDAVP may be required. Patients are very sensitive, use 0.04 mcg IV in the acute phase, usual dose 0.1mcg as required

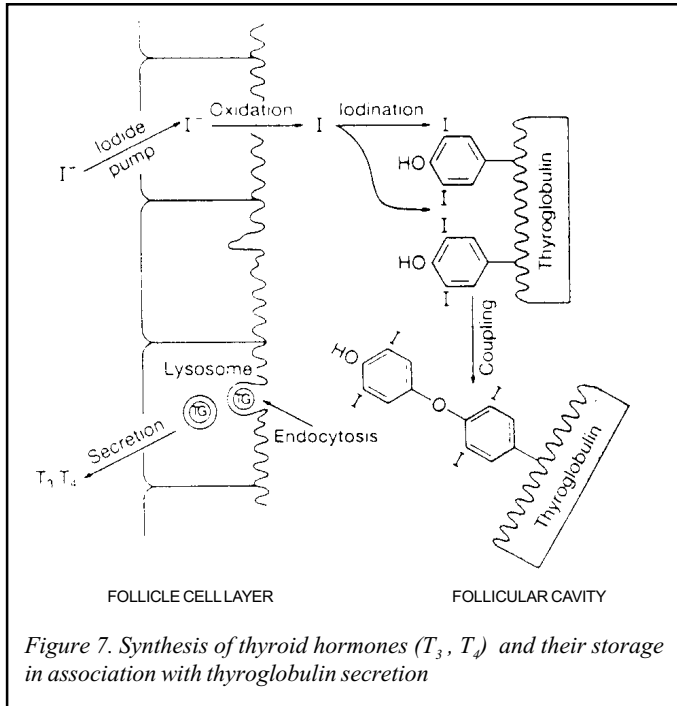

Figure 7. Synthesis of thyroid hormones ( $T_3$ ,  $T_4$ ) and their storage in association with thyroglobulin secretion

growth factors but their physiological relevance remains to be demonstrated.

Iodide supply is monitored through its effects on the plasma level of thyroid hormone and in the thyroid itself, where it depresses the response of the thyroid cells to TSH. Large doses of iodine inhibit the release of thyroglobulin bound hormones and thereby reduce the vascularity of the gland. For this reason, iodine was given to hyperthyroid patients before surgery.

Thyroid hormone plasma levels and action are monitored by the supraoptic nuclei in the hypothalamus and by cells of the anterior lobe of the pituitary. Thyrotrophin-releasing hormone (TRH) is transported from the hypothalamus to the pituitary via the hypophyseal portal vessels and stimulates the secretion of TSH. Rising levels of  $T_3$  and  $T_4$  reduce the secretion of TRH and TSH - negative feedback mechanism (figure 8)

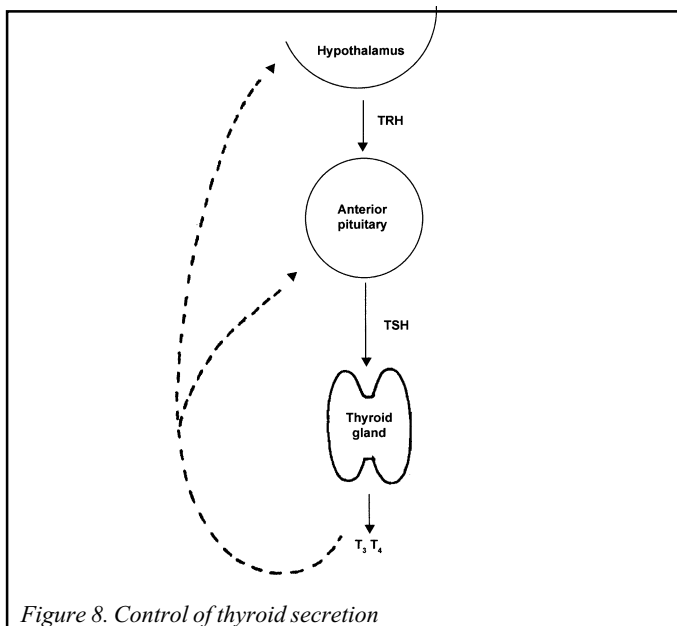

Figure 8. Control of thyroid secretion

**Actions of thyroid hormones**

Thyroid hormones exert their effects by binding to specific receptors, in the nuclei of cells in target tissues. They are involved in metabolism, thermogenesis, growth, development and myelination in childhood.

Oxidative metabolism, basal metabolic rate and therefore heat production is stimulated by  $T_3$  and  $T_4$ . They are essential for normal growth in childhood and neonatal deficiency results in severe mental retardation (cretinism). Classical symptoms and signs of hypothyroidism include cold intolerance, lethargy, obesity, hoarseness, bradycardia and a low metabolic rate. Overproduction of thyroid hormones results in hyperthyroidism which is characterised by heat intolerance, loss of weight, hyperexcitability, tachycardia and exophthalmos. An enlarged thyroid gland, or goitre, may be associated with hyperthyroidism (Graves' disease) and retrosternal extension of the goitre may cause tracheal compression.

**ADRENAL PHYSIOLOGY**

The adrenal glands are complex multi-functional organs whose secretions are required for maintenance of life. Failure of the adrenal glands leads to derangement in electrolyte and carbohydrate metabolism resulting in circulatory collapse, hypoglycaemic coma and death.

Each adrenal gland is situated on the superior aspect of each kidney and consists of two endocrine organs (figure 9). The inner adrenal medulla is mainly concerned with the secretion of the catecholamines epinephrine (adrenaline), norepinephrine (noradrenaline), and dopamine in response to nerve impulses that pass along the preganglionic sympathetic nerves. The outer cortex secretes the steroid hormones, the glucocorticoids, mineralocorticoids and the sex hormones.

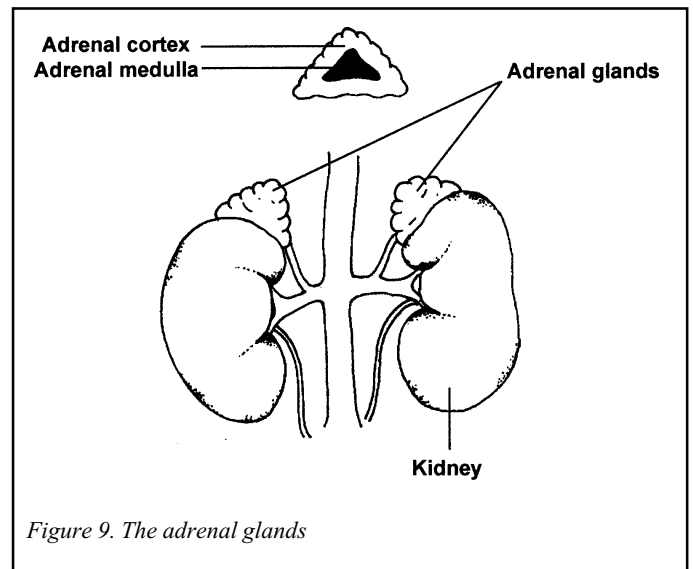

Figure 9. The adrenal glands

The adrenal cortex and medulla have separate embryological origins. The medullary portion is derived from the chromaffin ectodermal cells of the neural crest, which split off early from the sympathetic ganglion cells, while cells of the adrenal cortex are derived principally from coelomic mesothelium.

The adrenal glands are very vascular, the arterial blood supply coming from branches of the renal and phrenic arteries and the aorta. The medulla receives blood from the cortex rich in corticosteroids, which regulate the synthesis of the enzymes that converts norepinephrine to epinephrine. Venous drainage is mainly via the large adrenal vein into either the renal vein or inferior vena cava.

### Adrenal Medulla

The adrenal medulla is a modified sympathetic ganglion made up of densely innervated granule containing cells and constitutes about 30% of the mass of the adrenal gland. Approximately 90% of cells are epinephrine secreting cells while the other 10% are mainly the norepinephrine secreting cells. It is still unclear as to which type of cells secrete dopamine. Small collections of chromaffin cells are also located outside the medulla, usually adjacent to the chain of sympathetic ganglia.

### Synthesis

The pathways for the biosynthesis of dopamine, norepinephrine and epinephrine are shown in figure 10. They are stored in membrane-bound granules and their secretion is initiated by the release of acetylcholine from sympathetic nerve fibres that travel in the splanchnic nerves. Catecholamines have an extremely short half-life in the plasma of less than 2 minutes. Clearance from the blood involves uptake by both neuronal and nonneuronal tissues where they are either recycled or degraded by either monoamine oxidase or catechol-O-methyltransferase. About 50% of the secreted catecholamines appear in the urine as free or conjugated metanephrines and normetanephrines and about 35% as vanillylmandelic acid (VMA).

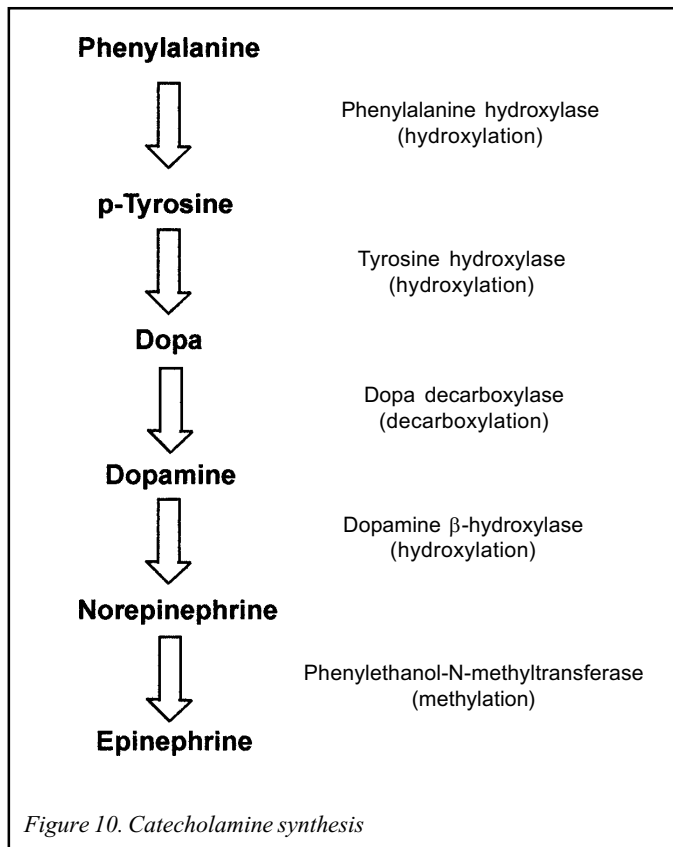

Figure 10. Catecholamine synthesis

### Effects

The actions of norepinephrine and epinephrine are numerous and complex and depend on their binding to  $\alpha$  ( $\alpha_1$ ,  $\alpha_2$ ) and  $\beta$  ( $\beta_1$ ,  $\beta_2$ ) adrenergic receptors while dopamine also acts at specific dopaminergic receptors (*The Autonomic Nervous System, Update in Anaesthesia 1995; No 5:3-6*). The individual actions at these receptors are beyond the scope of this article. They mimic the effects of noradrenergic nervous discharge, stimulate the nervous system, and exert metabolic effects that include glycogenolysis in the liver and skeletal muscle, mobilisation of free fatty acids, increase plasma lactate and increase the metabolic rate. Norepinephrine causes a marked increase in peripheral vascular resistance as a result of widespread vasoconstriction, while epinephrine causes vasoconstriction in skin and viscera but vasodilatation in skeletal muscle so that total peripheral resistance may decrease. While the direct effect of both is an increase in heart rate, the administration of norepinephrine results in reflex bradycardia due to the marked increase in peripheral resistance and mean arterial pressure. They increase alertness, although in humans epinephrine frequently evokes anxiety and fear.

### Control of adrenal medullary secretions

Catecholamine secretion is low in basal states and is further reduced during sleep. Secretion is initiated by sympathetic activity controlled by the hypothalamus and occurs in response to pain, anxiety, excitement, hypovoleamia and hypoglycaemia. With emergency stimulation you get diffuse medullary secretion preparing the person for the fight or flight response.

### Disorders of adrenomedullary function

Phaeochromocytomas arise from chromaffin cells in the adrenal medulla and in other paraganglia of the sympathetic nervous system. They are usually benign tumours and the clinical features depend on the activity of the tumour and the relative amounts of epinephrine and norepinephrine secreted. Typical signs and symptoms may include hypertension, hyperglycaemia, headache, palpitations, sweating, pallor and nausea.

Definitive treatment generally involves surgical removal of the tumour.

### Adrenal cortex

The adrenal cortex is responsible for the secretion of the glucocorticoids, mineralocorticoids and androgens (sex hormones). Glucocorticoids affect the metabolism of carbohydrates, fats and proteins and are important in mediating the response to fasting and stress. Mineralocorticoids are essential for sodium balance and consequently extracellular fluid balance. Androgens have a minor role in reproductive function when compared to the pituitary hormones, FSH and LH.

Histologically the adrenal cortex is divided into three distinct layers. The outer most layer contains the cells of the zona glomerulosa, the middle layer, the largest layer, contains the cells of the zona fasciculata, while the innermost layer contains the cells of the zona reticularis. All 3 zones secrete corticosterone, while, in contrast, aldosterone biosynthesis occurs in the zona glomerulosa. The enzyme mechanism for forming cortisol (hydrocortisone) and androgens is mainly found in the 2 inner zones.



### **Synthesis**

The hormones produced by the adrenal cortex contain the cyclopentanoperhydrophenantrene nucleus with the glucocorticoids and mineralocorticoids containing 21 carbon atoms and the androgens 19. The precursor of all steroid hormones is cholesterol. ACTH releases cholesterol from lipid droplets in the cytoplasm of the cells. It is converted in the mitochondria to pregnenolone. This is the rate limiting step in the biosynthesis of the steroidal hormones and is again regulated by ACTH. The pregnenolone is then transferred to the smooth endoplasmic reticulum where it undergoes further modification to form the three main classes of steroids. The actions of ACTH are thought to be mediated by cyclic-AMP. While several steroids have been identified, the steroids that are secreted in clinically significant amounts are aldosterone, the glucocorticoids cortisol and corticosterone, and the androgens dehydro-epiandrosterone and androstenedione. The adrenal glands can also produce small amounts of estrogens.

The corticosteroids in the circulation are mainly bound to plasma proteins such as corticosteroid-binding globulin (transcortin) and albumin. Inactivation of the hormones occurs mainly in the liver where they are conjugated with glucuronic acid or sulphate and excreted in the urine.

### **Actions of glucocorticoids**

Glucocorticoids play a vital role in the control of carbohydrate, fat and protein metabolism. They promote glycogen storage in the liver. During fasting they promote gluconeogenesis in the liver to provide glucose for brain metabolism. They are counter-regulatory to insulin, resulting in elevated blood glucose. Glucocorticoids potentiate the vasoconstrictor effects of catecholamines and decrease the permeability of vascular endothelium essential for maintenance of normal vascular function. Cortisol release increases during stress, and in patients with adrenocortical insufficiency absence of this response can result in hypotension and death. The glucocorticoids also have some mineralocorticoid activity. They have been shown to have anti-inflammatory properties and can suppress the immune response.

### **Regulation of adrenal cortical function**

Secretion of the glucocorticoids is controlled by ACTH produced by the anterior pituitary (figure 5). This is controlled by the hypothalamic secretion of corticotropin-releasing hormone (CRH) into the hypophyseal portal system. The release of cortisol exerts a negative feedback effect on both the anterior pituitary and the hypothalamus. Plasma cortisol levels follow a diurnal pattern, peak levels occurring in the morning just before waking.

### **Actions of mineralocorticoids**

Aldosterone and the other steroids with mineralocorticoid activity (corticosterone, deoxycorticosterone) increase the reabsorption of sodium acting mainly on the distal tubules of the kidney, resulting in the retention of sodium in extracellular fluids. Sodium is in effect exchanged for potassium and hydrogen, resulting in a potassium diuresis and an acidic urine. In adrenal insufficiency, sodium is lost in the urine while potassium is retained

resulting in raised plasma potassium. Plasma volume may also be reduced resulting in hypotension and circulatory insufficiency. The renin-angiotensin system has a major role in the maintenance of blood volume and electrolyte balance (*Physiology of the Kidney, Update in Anaesthesia 1998; No 9:24-28*)

### **Regulation of aldosterone secretion**

The main factors regulating aldosterone secretion are the renin-angiotensin system, ACTH from the pituitary, and the effects of a rise in plasma potassium or a fall in plasma sodium, which results in a direct stimulatory effect on the adrenal cortex.

Aldosterone is only one of many factors affecting sodium secretion. Other major factors include the glomerular filtration rate, atrial natriuretic peptide (ANP) and changes in tubular reabsorption of sodium independent of aldosterone. It is likely that the primary function of the aldosterone secreting mechanism is in the maintenance of the intravascular volume, although there are several other mechanisms involved.

### **Disorders of adrenocortical function**

Cushing's syndrome is the result of excess corticosteroids, the commonest cause being prolonged treatment with relatively large doses. Apart from the iatrogenic causes this disorder is very rare, other causes being primary tumours of the adrenal gland, adenoma or hyperplasia of the pituitary gland. In addition Cushing's syndrome can be secondary to carcinomas elsewhere, such as oat cell carcinoma of the lung, due to uncontrolled ACTH secretion, the 'ectopic ACTH syndrome'. Conn's syndrome is also very rare, caused by a benign adenoma or hyperplasia of the zona glomerulosa producing excess aldosterone.

Acute adrenal insufficiency can occur after trauma, severe hypotension and sepsis. It may follow surgical removal of the adrenals unless there is adequate replacement therapy. Chronic adrenal insufficiency (Addison's disease) occurs when there is destruction of the adrenal gland, caused by autoimmune disease, secondary tumour infiltration, tuberculosis or amyloidosis.

Excess androgen secretion causes masculinisation (adrenogenital syndrome). This can result from an androgen secreting adrenocortical tumour or due to a congenital enzyme defect affecting cortisol synthesis. In the latter case, the resulting decrease in circulating cortisol stimulates the overproduction of ACTH, which in turn stimulates the adrenals to produce excess androgenic steroids. Females show signs of virilisation while males show precocious puberty. Extreme feminisation in males can occasionally be due to an oestrogen producing tumour of the adrenal gland.

Table 1 summarises the more common disorders of adrenocortical function.

### **Conclusion**

The anaesthetist should, obviously, have a basic understanding of the physiology of the pituitary, thyroid and adrenal when involved with the management of patients with endocrine disease. Furthermore, this knowledge is fundamental to understanding the metabolic changes that occur following the stress of surgery.

Table 1. Disorders of adrenocortical function

Hormone	Syndrome	Symptoms & Signs
Glucocorticoid excess	Cushing's syndrome	Moon facies, truncal obesity, buffalo hump, abdominal striae, muscle weakness & wasting, hypertension, diabetes mellitus, hypokalemia and metabolic alkalosis.
Mineralocorticoid excess	Conn's syndrome	K <sup>+</sup> depletion, Na <sup>+</sup> retention, polyuria and hypokalemic alkalosis, hypertension, tetany & weakness.
Adrenocortical insufficiency (Adrenocortical atrophy due to autoimmune diseases or diseases of the adrenal gland)	Addison's disease	Skin pigmentation, Na <sup>+</sup> depletion, decreased plasma volume, weakness, tiredness and weight loss.
Adrenal androgen excess (Androgen secreting tumour, or congenital)	Adrenogenital syndrome	<i>In women:</i> hirsutism, acne, oligomenorrhea & virilisation.
	Congenital adrenal hyperplasia	<i>In male:</i> precocious puberty.

### Further Reading

1. Brady JJ, Cragg PA, MacKnight ADC, Mills RG. Lecture notes on Human Physiology. 4th edition, 1999.
2. Farling P. Thyroid disease. British Journal of Anaesthesia 2000; **85**: 15-28
3. Ganong WF. Review of Medical Physiology. 19th edition, 1999.
4. Goodman HM. Basic Medical Endocrinology. 2nd edition, 1994.
5. Guyton AC, Hall JE. Textbook of Medical Physiology. 9th edition, 1996.
6. Smith M Hirsch P. Pituitary disease and anaesthesia. British Journal of Anaesthesia 2000; **85**: 3- 14
7. (A good example of an internet resource is [www.thyroidmanager.org](http://www.thyroidmanager.org))

## BOOK REVIEW - FIELD ANAESTHESIA - BASIC PRACTICE

Written and Edited by Eric Vreede. Email: [guide.anaesthesia@msf.org](mailto:guide.anaesthesia@msf.org)

This 77 page booklet has been written as an introduction for anaesthetists planning to provide field anaesthesia. It assumes a basic knowledge of anaesthetic practice and deals with how to integrate modern anaesthetic practice into the field situation. The book is filled with practical information about the difficulties involved, and lists many of the solutions and different techniques which can be used.

The book is written in a didactic style which is easily understood. Many boxed points add clarity and emphasis to the basic text. There are 14 chapters and 21 tables. Most aspects of field anaesthesia are covered including preoperative care, triage and resuscitation, practical anaesthetic techniques and postoperative care. Basic equipment is discussed along with useful guidance on essential drugs and their doses. There are separate sections on ketamine, regional, obstetric and paediatric anaesthesia.

This short book is not intended to stand alone as a complete anaesthesia handbook but to make practical suggestions to support trained anaesthetists as they adapt to field anaesthesia. It contains much useful information from an experienced author and is strongly recommended. It costs £5

Iain Wilson

Published by Medecins sans Frontiers - Service medical  
8 Rue Saint-Sabin - 75544 Paris, Cedex 11 - France  
Tel +33 (0) 1 40212929 Fax +33 (0) 1 48066868  
UK office: +44 20 77135600

## ANAESTHESIA FOR PATIENTS WITH CARDIAC DISEASE UNDERGOING NON-CARDIAC SURGERY

Dr Sock Huang Koh, Queen Elizabeth Hospital, Birmingham,  
Dr James Rogers, Frenchay Hospital, Bristol

### INTRODUCTION

Major surgery stresses the cardiovascular system in the perioperative period. This stress leads to an increase in cardiac output which can be achieved easily by normal patients, but which results in substantial morbidity and mortality in those with cardiac disease. Postoperative events which cause death include myocardial infarction (MI), arrhythmias, and multiple organ failure secondary to low cardiac output. If the different mechanisms involved in different cardiac disease states are understood, then the most suitable anaesthetic can be given. The skill with which the anaesthetic is selected and delivered is more important than the drugs used. Previous articles on cardiovascular physiology and pharmacology (*Updates 10 & 11*) provide background information and should be read in conjunction with this article.

### ASSESSMENT OF PERIOPERATIVE RISK

The Goldman Cardiac Risk Index attempts to quantify the risk of adverse perioperative cardiac events (Table 1). The index scores each of a range of various conditions including cardiac disease, age and the nature and urgency of the proposed surgery. The total score predicts the likelihood of complications and death. For certain operations this risk can be minimised by avoiding general anaesthesia and using local anaesthetic techniques. Examples include peribulbar eye blocks for cataract surgery and brachial plexus blocks for upper limb surgery.

There have been more recent indices of risk, including one study of patients undergoing major elective non-cardiac surgery<sup>1</sup>. This identified six independent predictors of complications: high-risk type of surgery, history of ischaemic heart disease, history of

congestive cardiac failure, history of cerebrovascular disease, preoperative treatment with insulin, and a raised serum creatinine.

The American Heart Association and College of Cardiology have issued guidelines for perioperative cardiovascular evaluation for non-cardiac surgery<sup>2</sup>, giving levels of risk to certain clinical markers, functional capacity, and types of surgery (Table 2). In addition to identifying the presence of cardiac disease, it is essential to determine severity, stability, and prior treatment of the disease.

It is important to remember that the above schemes to identify populations of high risk patients will not predict accurately the perioperative problems facing any particular individual. However, they do allow planning of perioperative care. Depending on available resources, this includes: (a) optimisation of medical treatment and specific perioperative drug therapy, (b) preoperative surgical treatment of ischaemic and valvular disease, and (c) use of postoperative intensive care facilities.

### ISCHAEMIC HEART DISEASE (IHD)

In developed countries 5-10% of patients presenting for surgery have some degree of ischaemic heart disease. Patients with IHD are at increased risk of perioperative myocardial infarction (MI), which is associated with an in-hospital mortality of some 30%. This is usually the consequence of "silent" myocardial ischaemia, that is ischaemia without the characteristic symptoms of angina. The strong association between postoperative silent ischaemia and other adverse cardiac events makes it important to use anaesthetic techniques which minimise the chance of such ischaemia developing.

#### Pathophysiology

Ischaemic heart disease is the result of the build-up in larger coronary arteries of plaques of atheroma - consisting of cholesterol and other lipids. This causes narrowing of the vessels, restricting coronary blood flow. There may be insufficient myocardial blood supply during times of high demand eg exercise, leading to the effort related chest pain of stable angina. The more serious conditions of unstable angina (pain at rest), silent ischaemia and myocardial infarction are thought to be due to rupture of the atheromatous plaques causing thrombus formation, as well as vasoconstriction of the coronary vessels. There are several factors in the perioperative period which make these more likely:

- high levels of adrenaline and other catecholamines as a consequence of surgery, causing tachycardia, coronary vasoconstriction, and increasing platelet "stickiness".
- an increased tendency for blood to coagulate, making thrombosis in coronary vessels more likely.

Table 1. Goldman Cardiac Risk Index

3rd heart sound / elevated JVP	11 points	
MI within 6 months	10 points	
Ventricular ectopic beats >5/min	7 points	
Age > 70 years	5 points	
Emergency operation	4 points	
Severe aortic stenosis	3 points	
Poor medical condition	3 points	
Abdominal or thoracic operation	3 points	
<b>Score</b>	<b>Incidence of death</b>	<b>Incidence of severe CVS complications</b>
<6	0.2%	0.7%
<26	4%	17%
>25	56%	22%

Table 2. Predictors of Cardiac Risk

**Clinical Markers**

*Major predictors:* recent MI, unstable angina, untreated heart failure, significant arrhythmias and severe valvular disease.

*Intermediate predictors:* mild angina, history of MI, treated heart failure, and diabetes.

*Minor predictors:* old age, abnormal ECG, non-sinus rhythm, history of stroke, and uncontrolled hypertension.

**Functional Capacity**

This is a measure of the metabolic demands of various daily activities on the heart. For example, a patient who was breathless at rest, or after walking a short distance, would have a low functional capacity, which is a predictor of increased risk.

**Type of Surgery**

*High risk surgery:* major emergencies, aortic and vascular, peripheral vascular, and prolonged procedures particularly with fluid shifts and blood loss.

*Intermediate risk surgery:* carotid endarterectomy, head and neck, abdominal, thoracic and orthopaedic.

*Low risk surgery:* cataract, breast, and superficial procedures.

**Anaesthesia**

All anaesthetic techniques must aim to keep myocardial oxygen supply greater than demand, and therefore avoid ischaemia. The relevant factors are summarized in Table 3.

The essential requirements of **general anaesthesia** for IHD are avoiding tachycardia and extremes of blood pressure, both of which adversely affect the balance between oxygen supply and demand. These are discussed in detail below during each phase of an operation.

● **Pre-medication.** A nervous patient may be tachycardic and require an anxiolytic premedication. Beta-blockers also reduce tachycardia, and prevent perioperative myocardial ischaemia. A regime of intravenous atenolol followed by postoperative oral treatment resulted in a reduction in both morbidity and mortality for two years after surgery in IHD patients<sup>3</sup>. In a similar fashion, alpha2-agonist drugs such as clonidine reduce noradrenaline release from synapses, causing both sedation and analgesia, also a reduction in intraoperative myocardial ischaemia.

● **Induction.** All intravenous anaesthetic agents have a direct depressant action on the myocardium, and may also reduce vascular tone. This causes hypotension (especially in the hypovolaemic patient), often with a compensatory tachycardia,, which may cause myocardial ischaemia. In general all agents can be used safely if given slowly in small increments. However, ketamine is unique in causing indirect stimulation of the sympathetic nervous system, leading to both hypertension (increased afterload) and tachycardia. This will be dangerous for a patient with IHD and should be avoided.

● **Intubation.** Laryngoscopy is a powerful stressor, causing hypertension and tachycardia. This can be avoided with a supplemental dose of intravenous induction agent or opioid eg alfentanil, just prior to laryngoscopy.

● **Maintenance.** Volatile agents have minimal effects on cardiac output, although they do reduce myocardial contractility, especially halothane. They cause vasodilation, and isoflurane has been implicated in the ‘coronary steal’ syndrome. The theory is that pre-stenotic vasodilation diverts blood away from already ischaemic areas of the myocardium. However, there is doubt as to the clinical significance of this phenomenon. Vagal stimulation due to halothane can cause bradycardias and nodal rhythms. Bradycardias can be beneficial by allowing greater coronary diastolic filling, providing blood pressure is maintained. Ether, despite being a direct myocardial depressant, causes indirect sympathetic stimulation with tachycardia, and therefore can aggravate ischaemia.

Table 3. Factors affecting myocardial oxygen supply and demand

Oxygen supply	Oxygen demand
<i>Heart rate</i> - diastolic time <i>Coronary perfusion pressure</i> - aortic diastolic blood pressure - ventricular end-diastolic blood pressure <i>Arterial oxygen content</i> - arterial oxygen partial pressure - haemoglobin concentration <i>Coronary artery diameter</i>	<i>Heart rate</i> <i>Ventricular wall tension</i> - preload - afterload <i>Contractility</i>

### Preoperative assessment of IHD

- The aim is to assess the severity of disease and the degree of impairment of myocardial function. The patient's exercise tolerance (functional capacity) and frequency of angina attacks are an indication of the severity of disease. Non-cardiac surgery is generally safe for patients with good exercise tolerance, even if they have minor or intermediate predictors of clinical risk (Table 1).
- The patient may already be on medication for angina or hypertension. These drugs include beta-blockers, nitrates, and calcium antagonists. These protect against the haemodynamic stresses of surgery and should be continued through the perioperative period. However, general anaesthesia may exaggerate the hypotensive actions of such drugs.
- An electrocardiogram (ECG) may show changes of a previous MI such as Q waves, or ST segment depression suggestive of ischaemia. However, a resting ECG may be normal in 50% of patients with IHD, and therefore cannot exclude serious underlying disease. An ECG will also detect conduction defects, ventricular hypertrophy, and arrhythmias such as atrial fibrillation. (See "ECG Monitoring in Theatre" Update 11).
- Anaemia is well tolerated in the general population, but can cause a critical reduction in myocardial oxygen supply in those with IHD - a haematocrit of 30% or more is recommended.
- Other investigations may be performed to supplement clinical findings, but may not be readily available
  - (a) an exercise ECG involves the patient exercising on a treadmill, therefore increasing myocardial oxygen demand and with ischaemia showing as ST segment depression
  - (b) patients who are unable to exercise may undergo pharmacologic stress testing - drugs are used to increase myocardial oxygen demand and radioisotope imaging techniques detect ischaemic areas
  - (c) an echocardiogram can detect abnormalities of ventricular wall movements, which are a sensitive indicator of ischaemia.

● **Analgesia.** High doses of opioids reduce the stressor response to surgery. Theoretically, non-steroidal anti-inflammatory drugs (NSAIDs) may have both a useful postoperative analgesic action and an anti-platelet effect which may reduce coronary thrombosis.

● **Reversal and recovery.** Reversal of muscle relaxation with a combined anti-cholinesterase/anti-muscarinic causes tachycardias, and extubation in itself is a stressor. Problems in the recovery phase which can cause ischaemia include; tachycardia, pain, hypothermia, shivering, hypoxia, and anaemia. These should be treated not just in the immediate postoperative period, but throughout the hospital admission. The use of supplemental oxygen in the postoperative period is one of the simplest, yet most effective measures in preventing myocardial ischaemia.

● **Monitoring.** As discussed above, the prime anaesthetic goals are to avoid tachycardias and extremes of blood pressure. It follows that it is most useful to monitor heart rate and blood pressure, also pulse oximetry to detect hypoxia. An ECG, if available, will give indications of arrhythmias, and ST segment depression may indicate ischaemia, although an observer will usually only detect the minority of such events. Rarely used techniques to detect ischaemia involve intraoperative transoesophageal echocardiography to assess ventricular wall motion abnormalities, and measuring serum troponin levels in the postoperative period.

The use of **regional anaesthetic** techniques has theoretical advantages: epidural anaesthesia reduces preload and afterload, coagulation responses, and in the case of thoracic epidurals, causes coronary vasodilation. These effects should reduce

perioperative myocardial ischaemia, but this is not supported by research. However, good epidural analgesia may reduce the incidence of tachycardias arising due to postoperative pain. In a patient with IHD, local anaesthetic techniques such as brachial plexus block should be encouraged in order that the haemodynamic responses to general anaesthesia are avoided. However, even under local anaesthesia, the patient will be subject to the stresses of the surgical procedure itself, which can have marked haemodynamic effects.

### HEART FAILURE

Heart failure is the inability of the heart to pump enough blood to match tissue requirements. It occurs in 1-2 % of the population, rising to 10% in the over 75 year old age group, and is associated with increased mortality following anaesthesia. The commonest cause is ischaemic heart disease. Other causes include hypertension, valvular heart disease and cardiomyopathies. One third of untreated patients with an ejection fraction of less than 40% will die within a year.

### Pathophysiology

Cardiac output is lower in heart failure because stroke volume is reduced for the same left ventricular end-diastolic volume as compared to a normal heart. Starling's law of the heart demonstrates the relationship between ventricular end-diastolic volume and stroke volume (Figure 1). Since the failing heart has a limited ability to increase stroke volume, the only response to a greater preload is an increase in heart rate, which in turn can cause ischaemia. In addition, high end-diastolic ventricular pressures tend to oppose blood flow to the endocardium.

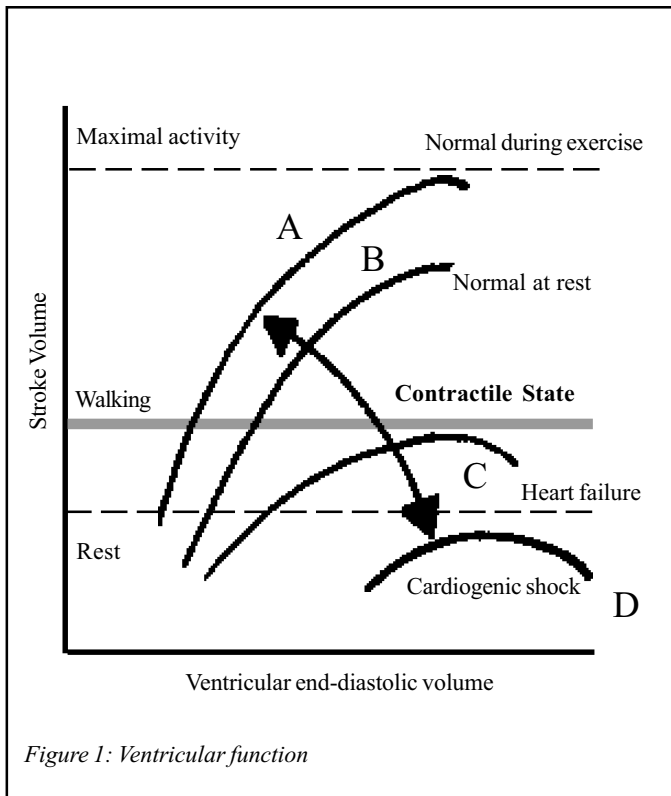

Curves A and B illustrate the rise in cardiac output with increases in ventricular end-diastolic volume (pre-load) in the normal heart. Note that with an increase in contractility there is a greater cardiac output for the same ventricular end-diastolic volume.

In the diseased heart (C and D), cardiac output is less, and falls if ventricular end-diastolic volume rises to high levels, as in heart failure or overload.

### Preoperative assessment

The aim is to assess disease severity and myocardial contractility. Limited exercise tolerance, orthopnoea, and paroxysmal nocturnal dyspnoea are indicators of disease severity. Drug treatments may include ACE (angiotensin converting enzyme) inhibitors, diuretics and nitrates. In some patients with mild to moderate heart failure, cardioselective beta blockers may be used in an attempt to control the heart rate, but the risk is that they may block the low level sympathetic nervous activity which maintains contractility in the failing heart. Useful investigations are an ECG (looking for evidence of ischaemia), CXR, and, if available, an echocardiogram to assess ejection fraction. This is the proportion of end-diastolic blood volume ejected by the left ventricle during systole, and values of less than 30% equate to severe heart failure.

### Anaesthesia

Safe anaesthesia for a patient in heart failure involves:

- Optimisation of ventricular filling - preload can be reduced with diuretics and nitrates, and both central venous and pulmonary artery pressures can be monitored. Trans-oesophageal echocardiography, if available, is a useful tool to visualize overall cardiac performance.

- Maintenance of myocardial contractility - in particular inotropes may be needed to oppose the cardiodepressant action of anaesthetic agents.

- Reduction of afterload by vasodilation, for example as a secondary effect of spinal or epidural anaesthesia. This not only reduces myocardial work, but helps maintain cardiac output. However, the benefit of such actions may be limited by falls in blood pressure which can compromise blood flow to vital organs such as the brain and kidneys.

### VALVULAR HEART DISEASE

Pathology affecting valves on the left side of the heart is more common than on the right side. The same general principles of providing a haemodynamically stable anaesthetic apply as outlined in the section on ischaemic heart disease. In general, patients with valvular disease require antibiotic prophylaxis against infective endocarditis when undergoing certain operations (Table 4). Symptomatic regurgitant disease is usually better tolerated in the perioperative period than stenotic lesions, which sometimes need treatment such as valvotomy prior to non-cardiac surgery.

### AORTIC STENOSIS

With a narrowed aortic valve, left ventricular (LV) outflow obstruction occurs. LV hypertrophy develops in compensation. This leads to reduced compliance, which is a reduction in ventricular wall movement for a fixed end-diastolic pressure. The eventual result is a fixed low cardiac output and inability to cope with systemic vasodilation. Coronary blood flow is also compromised due to the raised LV end-diastolic pressure. In addition to hypertrophy LV dilatation may also result, further reducing cardiac output. Aortic stenosis may result from rheumatic fever, often in association with the mitral valve. It may also be congenital, presenting in middle age, or be degenerative due to calcification in the elderly.

Symptoms of aortic stenosis usually occur when the valve area falls below  $1\text{cm}^2$  (normal  $2\text{-}3\text{cm}^2$ ), including angina, syncope on exertion, and symptoms of heart failure (dyspnoea, orthopnoea and paroxysmal nocturnal dyspnoea). Symptoms suggestive of aortic stenosis are angina and syncope on exertion, and symptoms of LV failure (dyspnoea, orthopnoea and paroxysmal nocturnal dyspnoea). An ECG will show signs of LV hypertrophy and strain, and an echocardiogram will assess (a) the pressure gradient between the LV and the aortic root, and (b) the LV contractility.

Anaesthesia may precipitate myocardial ischaemia or arrhythmias in patients with aortic stenosis. LV failure may also result. In the absence of treatment, sudden death occurs in 15-20%.

### Anaesthesia

The aim is to maintain haemodynamic stability, in particular perfusion of the coronary vessels which are dependent on aortic root diastolic blood pressure. It is important to avoid reducing the systemic vascular resistance by vasodilation, but also not to cause excessive vasoconstriction. Tachycardia, myocardial depression and non-sinus rhythm (with consequent loss of the atrial contribution to ventricular filling) are all adverse factors. Spinal and epidural anaesthesia causes falls in systemic vascular resistance, and is therefore relatively contraindicated.

Table 4. Prevention of endocarditis in patients with heart-valve lesion, septal defect, patent ductus, or prosthetic valve. Guidelines from the British National Formulary 2002.

**Dental procedures under local or no anaesthesia,**

- patients who have not received more than a single dose of a penicillin in the previous month, including those with a prosthetic valve (but not those who have had **endocarditis**), oral amoxicillin 3 g 1 hour before procedure; CHILD under 5 years quarter adult dose; 5–10 years half adult dose
- patients who are penicillin-allergic or have received more than a single dose of a penicillin in the previous month, oral clindamycin 600 mg 1 hour before procedure; CHILD under 5 years clindamycin 150 mg *or* azithromycin 200 mg; 5–10 years clindamycin 300 mg *or* azithromycin 300 mg
- patients who have had **endocarditis**, amoxicillin + gentamicin, as under general anaesthesia

**Dental procedures under general anaesthesia,**

- *no special risk* (including patients who have not received more than a single dose of a penicillin in the previous month),
  - *either* i/v amoxicillin 1 g at induction, then oral amoxicillin 500 mg 6 hours later; CHILD under 5 years quarter adult dose; 5–10 years half adult dose
  - *or* oral amoxicillin 3 g 4 hours before induction then oral amoxicillin 3 g as soon as possible after procedure; CHILD under 5 years quarter adult dose; 5–10 years half adult dose
- *special risk* (patients with a prosthetic valve or who have had **endocarditis**), i/v amoxicillin 1 g + i/v gentamicin 120 mg at induction, then oral amoxicillin 500 mg 6 hours later; CHILD under 5 years amoxicillin quarter adult dose, gentamicin 2 mg/kg; 5–10 years amoxicillin half adult dose, gentamicin 2 mg/kg
- patients who are penicillin-allergic or who have received more than a single dose of a penicillin in the previous month,
  - *either* i/v vancomycin 1 g over at least 100 minutes then i/v gentamicin 120 mg at induction or 15 minutes before procedure; CHILD under 10 years vancomycin 20 mg/kg, gentamicin 2 mg/kg
  - *or* i/v teicoplanin 400 mg + gentamicin 120 mg at induction or 15 minutes before procedure; CHILD under 14 years teicoplanin 6 mg/kg, gentamicin 2 mg/kg
  - *or* i/v clindamycin 300 mg over at least 10 minutes at induction or 15 minutes before procedure then oral or i/v clindamycin 150 mg 6 hours later; CHILD under 5 years quarter adult dose; 5–10 years half adult dose

**Upper respiratory-tract procedures**, as for dental procedures; post-operative dose may be given parenterally if swallowing is painful.

**Genito-urinary procedures**, as for *special risk* patients undergoing dental procedures under general anaesthesia except that clindamycin is not given, see above; if urine infected, prophylaxis should also cover infective organism.

**Obstetric, gynaecological and gastro-intestinal procedures** (prophylaxis required for patients with prosthetic valves or those who have had **endocarditis** only), as for genito-urinary procedures.

## AORTIC REGURGITATION

An incompetent aortic valve leads to retrograde flow of blood from the aorta to the LV during diastole. This results in LV dilatation and hypertrophy. Initially, there is an increase in stroke volume, but eventually aortic regurgitation results in LV failure and a low cardiac output state. Causes include ischaemic heart disease, degeneration, infection (rheumatic fever, syphilis, endocarditis), ankylosing spondylitis, aortic dissection, or it may be congenital. Symptoms of aortic regurgitation are the symptoms of LV failure. Angina may occur at a late stage. An ECG may show LV hypertrophy, with a large left ventricle on chest X-ray.

## Anaesthesia

It is important to avoid bradycardia as this increases the time for regurgitation and reduces forward flow and hence cardiac output. Peripheral vasoconstriction and increased diastolic pressure also increase the regurgitant flow. Conversely, vasodilation encourages forward flow of blood.

## MITRAL STENOSIS

Patients become symptomatic when the mitral valve area falls from the normal of 4–6cm<sup>2</sup> to 1–3cm<sup>2</sup>. The obstruction leads to left atrial (LA) hypertrophy and dilation. LV filling is also reduced, hence

<i>Examples of causes of perioperative myocardial ischaemia</i>		
<b>Preoperative</b>	<b>Intraoperative</b>	<b>Postoperative</b>
Anxiety	Tachycardia	Pain
Pain	Extremes of blood pressure	Hypoxia
Hypovolaemia	Anaesthetic agents	Hypothermia
Inadequate drug treatment	Surgical stresses	Anaemia
		Hypercoagulability

reducing cardiac output. Within the pulmonary circulation, pulmonary vascular resistance increases due to pulmonary congestion, reducing lung compliance. Pulmonary hypertension results. Atrial fibrillation occurs in 50% of patients with mitral stenosis due to the LA enlargement. Causes of mitral stenosis are rheumatic fever, infection, inflammatory conditions and it may be congenital. Arrhythmias, pulmonary oedema and myocardial ischaemia can occur during anaesthesia.

Symptoms include those of LV failure, in particular dyspnoea and haemoptysis. ECG changes are those of LA (P mitrale) and perhaps RV hypertrophy. A chest X-ray may show LA enlargement and pulmonary oedema, and an echocardiogram can demonstrate the presence of left atrial thrombus. Patients with mitral stenosis may be on digoxin and warfarin, so a clotting screen should show appropriate values for the proposed surgery, and hypokalaemia should be avoided since it can cause digoxin toxicity.

### **Anaesthesia**

The anaesthetic goals are to prevent tachycardia, which allows less time for diastolic flow through the stenosed valve, and to try to preserve sinus rhythm. In addition, it is important to maintain cardiac output and avoid hypovolaemia and vasodilation, which cause reduced atrial and ventricular filling. Raised pulmonary vascular resistance can inadvertently be further increased by hypercarbia and hypothermia, which should be avoided.

### **MITRALREGURGITATION**

The incompetent mitral valve allows retrograde flow of blood from the LV to the LA, resulting in LA dilation. Pulmonary oedema then develops. Atrial fibrillation occurs in severe cases. Rheumatic fever accounts for 50% of cases, with other causes including myocardial infarction (secondary to papillary muscle rupture), degenerative changes, bacterial endocarditis, ruptured chordae tendinae, and cardiomyopathies. The main symptom is dyspnoea. ECG changes are similar to those seen in mitral stenosis, and a

chest X-ray may show cardiac enlargement and pulmonary oedema.

Mitral valve prolapse is the most common valvular abnormality, occurring in 3-8% of the population, in which one of the mitral valve leaflets prolapses into the left atrium. Mitral regurgitation and autonomic dysfunction may be associated with this condition, but otherwise there are no significant anaesthetic implications.

### **Anaesthesia**

The aim is to maintain cardiac output and reduce the regurgitant flow. Therefore, myocardial depression and hypovolaemia should be avoided. Bradycardias and systemic vasoconstriction will increase regurgitant flow.

### **Summary**

Patients with cardiac disease present for anaesthesia every day. Since their perioperative courses are associated with greater morbidity and mortality, it is important to provide a haemodynamically stable anaesthetic. This requires knowledge of the pathophysiology of the disease, and of the drugs and procedures and their effects on the patient.

### **References**

1. Lee TH et al. Derivation and Prospective Validation of a Simple Index for Prediction of Cardiac Risk of Major Noncardiac Surgery. *Circulation* 1999; **100**: 1043-1049
2. Eagle KA et al. Guidelines for Perioperative Cardiovascular Evaluation for Noncardiac Surgery. *Circulation* 1996; **93**: 1278-1317
3. Mangano D, Layug E, Wallace A, Tateo I. Effect of Atenolol on Mortality and Cardiovascular Morbidity after Noncardiac Surgery. *New England Journal of Medicine* 1996; **335(23)**: 1713-1720



## ASA AND CEPOD SCORING

Dr Richard Walker, Ashburton, UK

Several scoring systems have been devised to describe patients scheduled for surgery and anaesthesia, the best known are the ASA and the CEPOD scores.

The American Association of Anaesthetists (ASA) score subjectively categorises patients into five subgroups by preoperative physical fitness. It was devised in 1941 by the ASA as a statistical tool for retrospective analysis of hospital records. Since inception it has been revised on several occasions and now also includes an "E" suffix denoting an emergency case.<sup>[1]</sup>

ASA classification makes no adjustment for age, sex, weight, or for pregnancy, nor does it reflect the nature of the planned surgery, the skill of the anaesthetist or surgeon, the degree of pre-theatre preparation or facilities for postoperative care. The ASA score does not give a prediction of risk for a particular patient or operation. Since underlying fitness is an important predictor of survival from surgery, the ASA score has some correlation with outcome. As it is simple and widely understood, it is commonly used as a part of the preoperative assessment, and is an easy tool for audit.

In the UK patients are coded according to their ASA and CEPOD scores. These describe the patient from the perspectives of basic risk banding and urgency of surgery. The scores allow anaesthetists and surgeons to describe their workload which may be helpful for audit purposes. Research into perioperative outcome use these scores widely as descriptors of the surgical population.

Table 2. CEPOD Scores

<b>Grade 1</b>	<b>Elective</b> Operation at time to suit both surgeon and patient
<b>Grade 2</b>	<b>Scheduled</b> Operation within 24 hours. Delayed operation after resuscitation
<b>Grade 3</b>	<b>Urgent</b> Operation between 1 and 3 weeks. Early surgery preferred, but not life saving
<b>Grade 4</b>	<b>Emergency</b> Operation within 1 hour. Immediate operation or resuscitation simultaneous with surgical treatment

### References

1. Anon. New classification of physical status. *Anesthesiology* 1963;**24**:111
2. Buck N, Devlin HB, Lunn JN. The report of a confidential enquiry into perioperative deaths. The Nuffield Provincial Hospitals Trust and Kings Fund, London (1987)

Table 1 ASA Scores.

Class	Physical status	Example
I	A completely healthy patient	A fit patient with an inguinal hernia
II	A patient with mild systemic disease	Essential hypertension, mild diabetes without end organ damage
III	A patient with severe systemic disease that is not incapacitating	Angina, moderate to severe COPD
IV	A patient with incapacitating disease that is a constant threat to life	Advanced COPD, cardiac failure
V	A moribund patient who is not expected to live 24 hours with or without surgery	Ruptured aortic aneurysm, massive pulmonary embolism
E	Emergency case	

## CLINICAL USE OF BLOOD

Meena N. Cherian, Jean C. Emmanuel,  
Department of Blood Safety & Clinical Technology, World Health Organisation, Geneva, Switzerland.

Allogenic transfusion - blood transfused from a donor  
Autologous transfusion - blood transfused from the patient  
Normovolaemia - normal circulating blood volume

Blood used correctly can be life saving, used inappropriately it can endanger life. It is important to remember that blood transfusion is only one part of the patient's management. The decision to transfuse blood or blood products should always be based on a careful assessment of clinical and laboratory indications that transfusion is necessary to save life or prevent significant morbidity.

While the responsibility of providing and ensuring access to safe blood lies with the Blood Transfusion Services, the final responsibility for the blood transfusion lies with the clinicians (Anaesthetists, Surgeons, Obstetricians, and Physicians) who must make the correct decision depending on the clinical condition of the patient. In the operating room it is most often the anaesthetist, rather than the surgeon who makes the decision for blood transfusion. As anaesthetists are involved with a wide range of specialities including Trauma, Intensive Care, and often teach students at the undergraduate and postgraduate level, they may actively facilitate the appropriate clinical use of blood.

### AVAILABILITY OF BLOOD FOR TRANSFUSION

All anaesthetists need to be aware of the global status of blood transfusion. Even when blood is considered safe by current standards, it may contain unknown pathogens.

- In developed countries all donated blood is screened for blood borne pathogens. In developing countries only 53 % of the donated blood is tested for HIV and hepatitis B; a much smaller proportion is screened for hepatitis C.
- Between 5-10% of HIV infections worldwide are transmitted through the transfusion of contaminated blood and blood products. Hepatitis B and C viruses, syphilis and other infectious agents such as Chaga's disease infect many more recipients of blood products.
- Blood is in short supply. The 20% of the world population living in developed countries have access to 60% of the world blood supply. The 80% of world population living in developing countries have access to only 20% of the world blood supply of safe and tested blood.

### OXYGEN CARRIAGE IN BLOOD

Oxygen is carried in the blood in two forms. Most is carried combined with haemoglobin but there is a very small amount dissolved in the plasma. Each gram of haemoglobin can carry 1.31ml of oxygen when it is fully saturated. Therefore every litre of blood with a Hb concentration of 15g/dl can carry about 200mls

of oxygen when fully saturated (occupied) with oxygen ( $PO_2 > 100\text{mmHg}$ ). At this  $PO_2$  only 3ml of oxygen will dissolve in every litre of plasma. When considering the adequacy of oxygen delivery to the tissues, three factors need to be taken into account, haemoglobin concentration, cardiac output and oxygenation.

### Oxygen delivery to the tissues

The quantity of oxygen made available to the body's tissues in one minute is known as the oxygen delivery and is equal to the cardiac output x the arterial oxygen content.

Oxygen delivery (mls  $O_2$ /min) = Cardiac output (litres/min) x Hb concentration (g/litre) x 1.31 (mls  $O_2$ /g Hb) x % saturation

In the normal adult this works out as:  $5000\text{ml blood/min} \times 200\text{ml}O_2/1000\text{ml blood} = 1000\text{ml}O_2/\text{min}$ .

### The effect of haemorrhage on the oxygen supply

Several factors contribute to decreased oxygen supply to the tissues following haemorrhage. These are summarised in the following equation:

● Cardiac Output x ● Hb x ● Saturation = ●  $O_2$  supply to the tissues

When significant blood loss occurs, the fall in oxygen carrying capacity of blood together with the reduction in blood volume cause a fall in oxygen delivery. If intravenous therapy is started to maintain **normovolaemia**, a normal or increased cardiac output may occur which enables an adequate oxygen continue. Replacement of blood loss with crystalloids or colloids also results in dilution of the blood components or haemodilution. Initially this reduces the viscosity of blood, which improves capillary blood flow and cardiac output, enhancing the supply of oxygen to the tissues. Therefore the key objective is to ensure normovolaemia at all times during the course of a surgical procedure. When the Hb falls below 7-8g/dl the cardiac output can no longer compensate for the anaemia and blood transfusion is usually necessary.

### Blood volume replacement

To maintain blood volume, intravenous fluids should be given:

- Crystalloids such as normal saline or Ringer's lactate solution leave the circulation more rapidly than colloids. Use 3 times the estimated volume of blood lost.
- Colloids should be infused in an amount equal to the volume of blood lost.

- 5% dextrose produces little effect on blood volume and should not be used for acute blood loss.

### Indications for blood transfusion

The judgement on what is an adequate preoperative haemoglobin level for patients undergoing elective surgery must be made on an individual patient basis. It should be based on the clinical condition of the patient and the planned procedure. Accurate estimations of the blood loss and appropriate replacement are necessary to use blood appropriately.

### Estimating blood loss

In order to maintain blood volume accurately, it is essential to continually assess surgical blood loss throughout the procedure especially in neonates and children where even a very small amount lost can represent a significant proportion of blood volume (table 1).

Table 1

Blood	volume
Neonates	85-90ml/ kg body weight
Children	80ml/ kg body weight
Adults	70ml/ kg body weight

#### Calculating blood loss in theatre:

- Weigh a dry swab.
- Weigh blood soaked swabs as soon as they are discarded and subtract their dry weight (1ml of blood weighs approximately 1gm).
- Subtract the weight of empty suction bottles from the filled ones.
- Estimate blood loss into surgical drapes, together with the pooled blood beneath the patient and onto the floor.
- Note the volume of irrigation fluids, subtract this volume from the measured blood loss to estimate the final blood loss.

### Monitoring for signs of hypovolaemia

Many of the autonomic and central nervous system signs of significant hypovolaemia can be masked by the effects of general anaesthesia. The classic picture of the restless, tachycardic, confused patient who is hyperventilating (air hunger), in a cold sweat and complaining of thirst is not a presentation under general anaesthesia. Hypotension may result from a number of causes, but hypovolaemia should always be suspected.

### BLOOD TRANSFUSION

The decision to transfuse blood can be made in two ways:

- **Percentage method.** Calculate the patient's blood volume. Decide on the percentage of blood volume that could be lost but safely tolerated, depending on the clinical condition of the patient, provided that normovolaemia is maintained (table 2).

- **Haemodilution method.** Decide on the lowest acceptable Hb or Haematocrit (Hct) that may be safely tolerated by the patient (table 2). Using the following formula to calculate the allowable volume of blood loss that can occur before a blood transfusion becomes necessary. Replace blood loss up to the allowable volume with crystalloid or colloid fluids to maintain normovolaemia. If the allowable blood loss volume is exceeded, further replacement should be with blood.

$$\text{Allowable blood loss} = \frac{\text{Blood volume} \times (\text{PreopHb} - \text{Lowest acceptable Hb})}{\text{Average of Preop and Lowest Acceptable Hb}}$$

Whichever method is used, the decision to transfuse will depend on the clinical condition of the patient and their ability to compensate for a reduction in oxygen supply. This is particularly limited in patients with evidence of severe cardiac or respiratory disease or pre-existing anaemia. The methods described are simple guidelines which must be altered according to the clinical situation. Further blood loss should be anticipated, particularly postoperatively. Whenever possible, transfuse blood when surgical bleeding is controlled. This will maximise the benefits of the transfusion.

### What are the alternatives to allogenic blood transfusion?

If you anticipate that the planned surgery will result in sufficient blood loss to require transfusion consider whether any of the following are appropriate.

#### Autologous transfusion

**Preoperative donation.** A unit of the patient's own blood is collected every 5 - 7 days prior to the day of surgery. The blood is tested, labelled and stored to the same standard as allogenic blood and the patient is prescribed oral iron supplements. Up to 35 days preoperatively, a total of 3- 4 units of stored blood may be collected and then re-infused during surgery. This technique needs good organisation, and is not widely used.

**Normovolaemic haemodilution.** Removal of a predetermined volume of the patient's own blood immediately prior to the start of surgery. The blood is taken via a large cannula into a blood donation bag, which should be labelled and stored at room temperature for reinfusion within 6 hours. The blood is simultaneously replaced with crystalloid or colloid to maintain the blood volume. During the surgery the haemodiluted patient will lose fewer red cells for a given blood loss, and the autologous blood collected can subsequently be reinfused, preferably when surgical bleeding has been controlled. These fresh units of autologous blood will contain a full complement of coagulation factors and platelets. Current guidelines suggest that acute normovolaemic haemodilution should be considered when the potential surgical blood loss is likely to exceed 20% of the blood volume. Patients should have a preoperative haemoglobin of more than 10g/dl and not have severe cardiac disease.

#### Blood salvage

Blood salvage is the collection of shed blood from the wound or body cavity and its subsequent infusion into the same patient. Contraindications to salvage include blood contaminated with

Patient condition	Healthy	Average	Poor
<b>Percentage method</b> Acceptable loss of blood volume before transfusion method	30%	20%	<10%
<b>Haemodilution</b>	Hb 7-8g/dl Hct 21-24%	8-9g/dl 24-27%	10g/dl 30%

bowel contents, bacteria, fat, amniotic fluid, urine, malignant cells and irrigation fluids. One should not reinfuse salvaged blood more than 6 hours old, since haemolysis of red cells is likely to be complete.

#### Methods of blood salvage:

- Gauze filtration: using aseptic technique, blood is collected with a ladle or small bowl and filtered through a gauze into a bottle containing anticoagulant.
- Simple suction collection systems: suction pressure should be as low as possible to avoid hemolysis of red cells.
- Automated suction collection systems (cell savers): are commercially available and are routinely used for many operations associated with substantial blood loss in some countries. They collect, anticoagulate, wash, filter and re-suspend red cells in crystalloid fluid prior to re-infusion. The high cost of the equipment limits availability.

#### Minimising peri-operative blood transfusion

**Preoperative.** The screening and treatment of anaemia should be a key component of the preoperative management of elective surgical patients. Oral iron (ferrous sulphate 200mg three times a day (tds) for an adult and 15mg/kg/day for a child), will raise the haemoglobin level by about 2gm/dl within about 3 weeks in a patient with iron deficiency anaemia. If there are vitamin deficiencies these should also be corrected with oral folic acid (5mg daily) and injected vitamin B12 (hydroxocobalamin).

**In theatre.** The best way to avoid the need for transfusion is by minimising blood loss. A number of simple anaesthetic and surgical techniques may be used to achieve this objective. They include:

#### Anaesthetic techniques:

- Avoid hypertension and tachycardia due to sympathetic overactivity by ensuring adequate levels of anaesthesia and analgesia.
- Avoid coughing, straining and patient manoeuvres, which increase venous blood pressure.
- Avoid hypercarbia causing vasodilatation which will increase operative blood loss.
- Use regional anaesthesia, such as epidural and spinal anaesthesia where appropriate
- Avoid hypothermia in the perioperative period.
- Controlled hypotension in experienced hands.

#### Surgical techniques:

- Training, experience and care of the surgeon is the most crucial factor.
- Meticulous attention to bleeding points - use of diathermy
- Posture - the level of the operative site should be a little above the level of the heart e.g. Trendelenberg position for lower limb, pelvic and abdominal procedures. Head-up posture for head and neck surgery. Avoid air embolism if a large vein above heart level is opened during surgery.
- Tourniquets- the inflation pressure of the tourniquet should be approximately 100-150mmHg above systolic blood pressure of the patient. Tourniquet should not normally be used in patients with sickle cell disease or trait.
- Vasoconstrictors - infiltration of the incision site with adrenaline (with or without local anaesthetic agent). Avoid vasoconstrictors in end arteries e.g. fingers, toes and penis.
- Postoperative period - Give adequate analgesia because the postoperative pain can cause hypertension and restlessness, which can aggravate bleeding. E.g. following limb surgery, postoperative elevation will reduce swelling, control venous blood loss and reduce pain. Give iron supplements (ferrous sulphate 200mg tds) to restore Hb level.

#### Antifibrinolytic drugs:

- Drugs, which inhibit the fibrinolytic system and encourage clot stability, have been used in certain operations (e.g. repeat cardiac operations) to reduce operative blood loss, but are not widely used. Aprotinin, tranexamic acid are used when indicated.

#### Antiplatelet drugs:

- Drugs affecting platelet function e.g. Aspirin and NSAIDs (non steroidal anti-inflammatory drugs) should be discontinued 10 days prior to surgery associated with significant blood loss.

#### COMPLICATIONS OF MASSIVE BLOOD TRANSFUSION

**Definition:** Massive blood transfusion is the replacement of blood loss equivalent to or greater than the patient's total blood volume in less than 24 hrs:

- 70ml/kg in adults
- 80-90ml/kg in children or infants

It is often the underlying cause, and the end result of major haemorrhage, that cause complications, rather than the transfusion itself.

#### Complications include:

- **Acidosis** is more likely to be the result of inadequate treatment of hypovolaemia than the effects of transfusion. Normally the body can easily neutralise the acid load from transfusion. The routine use of bicarbonate or alkalinising agents based on the number of units transfused is unnecessary.
- **Hyperkalemia** is rarely of clinical significance (other than neonatal exchange transfusions).
- **Citrate toxicity and hypocalcaemia.** Citrate toxicity is rare, except in large volume, rapid transfusion of whole blood. Hypocalcaemia particularly in combination with hypothermia and acidosis can cause a reduction in cardiac output, bradycardia and other arrhythmias. Citrate is usually rapidly metabolised to bicarbonate. It is therefore, unnecessary to neutralize the acid load of transfusion. There is very little citrate in red cell concentrates and red cell suspensions.
- **Hypothermia** can occur with rapid administration of large volumes of blood or replacement fluids directly from the refrigerator. With rapid transfusions use a blood warmer.
- **Depletion of fibrinogen and coagulation factors.** Plasma undergoes progressive loss of coagulation factors (Factors V and VII) during storage unless stored at  $-25^{\circ}\text{C}$  or colder. Red cell concentrates and plasma- reduced units lack coagulation factors, which are found in the plasma component. Following administration of large volumes of replacement fluids there is dilution of coagulation factors and platelets. Massive or large volume transfusions can therefore result in disorders of coagulation. If there is prolongation of the prothrombin time (PT), give ABO- compatible fresh frozen plasma (15ml/kg). If APTT is also prolonged, Factor VII/fibrinogen concentrate is recommended in addition to the fresh frozen plasma (FFP).
- **Depletion of platelets** occurs during storage of whole blood and there is virtually no platelet function after 24 hours. Prophylactic use of platelets is not recommended. Give platelet concentrates only when the patient shows clinical signs of microvascular bleeding or the platelet count falls below  $50 \times 10^9/\text{L}$ . Consider platelet transfusion when the platelet count falls below  $20 \times 10^9/\text{L}$ , even when there is no clinical evidence of bleeding, because there is a risk of spontaneous internal haemorrhage.
- **Disseminated intravascular coagulation (DIC)** may develop during massive blood transfusion although its cause is less likely to be due to the transfusion than to the underlying reason for transfusion, such as hypovolaemia, trauma or obstetric complications.

#### Management of DIC:

- When DIC is suspected, do not delay treatment while waiting for the results of coagulation test. Treat the cause and use blood products to help control haemorrhage.
- If PT or APTT is prolonged and the patient is bleeding, replace red cell losses with the freshest whole blood available as it contains fibrinogen and most other coagulation factors. Give FFP as this

contains labile coagulation factors (1 pack / 15kg body weight i.e. 4-5 packs in adults). Repeat FFP according to the clinical response. This dose is based on preparation of FFP, cryoprecipitate and platelet concentrates from 450ml donations. FFP is always supplied as a separate pack for each donor, cryoprecipitate and platelets preparations are pooled donations.

- If fibrinogen is low or APTT or thrombin time is prolonged, also give cryoprecipitate, to supply fibrinogen and Factor VIII (1 pack / 6kg body weight i.e. 8-10 packs in adults).
- If platelet count is less than  $50 \times 10^9/\text{L}$  and the patient is bleeding, also give platelet concentrates (4-6 packs in adults).
- Heparin is not recommended in bleeding patients with DIC.

#### BLOOD TRANSFUSION REACTIONS

Most transfusion reactions are mild involving urticaria and moderate pyrexia. Acute, severe reactions may occur in 1-2% of transfused patients. **The most common cause of severe transfusion reactions is patients being given the wrong blood.** This may result from an incorrect sample being sent to the laboratory, a mix up in the transfusion department, but most frequently the wrong blood being transfused on the ward.

In an unconscious or anaesthetised patient, hypotension and uncontrolled bleeding may be the only signs of an incompatible transfusion. Other signs include tachycardia and haemoglobinuria. Even a small volume (10-50ml) of incompatible blood can cause a severe reaction and larger volumes increase the risk. Acute transfusion reactions occur during or shortly after (within 24 hrs) the transfusion. Rapid recognition and management of the reaction may save the patient's life.

#### Management of a severe reaction under anaesthesia

- Stop transfusion and treat as anaphylaxis
- Replace infusion set with normal saline.
- Maintain airway, give high flow oxygen.
- If there is severe hypotension or bronchospasm give adrenaline either IV (1:10,000 solution in 0.5-1ml aliquots) or IM (1:1000 as 0.01ml/kg body weight). Consider IV corticosteroids and bronchodilators.
- Give IV diuretic e.g. frusemide 1mg/kg.
- Immediately notify blood bank and send the blood pack with the infusion set, fresh urine sample, fresh venous blood sample (1 clotted and 1 anti-coagulated) from a vein opposite the infusion site.
- Assess and treat hypotension with saline 20-30ml/kg over 5 minutes and inotropes (e.g. dopamine).
- Monitor urine output. A falling urine output or a rising  $\text{K}^+$ , urea, or creatinine are indicative of acute renal failure. Ensure a normal blood pressure (a CVP measurement may be required) and consider further frusemide. Renal dialysis may be required.
- If bacteraemia is suspected (rigors, fever, collapse, no evidence of a haemolytic reaction) start IV broad-spectrum antibiotics.

## CHECKLIST FOR GIVING BLOOD

### Before you prescribe blood - ask yourself:

- What improvement am I aiming to achieve in this patient's clinical condition? Can I reduce blood loss to minimise this patient's need for transfusion?
- Have I given other treatment (e.g. intravenous replacement fluids, oxygen) before making the decision to transfuse blood?
- What are the specific clinical or laboratory indications for transfusion?
- What are the risks of transmitting HIV, hepatitis, syphilis or other infectious agents through the blood products that are available for this patient?
- Do the benefits of transfusion outweigh the risks of blood transfusion for this particular patient?
- What other options is there if no blood is available in time?
- In the postoperative period will a trained person monitor and respond immediately if any adverse transfusion reactions occur?
- Have I recorded my decision and reasons for transfusion on the patient's chart and Blood Request form?
- Finally, the most important question you should ask before making a decision - would I accept this transfusion in this clinical condition, if this blood was for myself or my child?

### Before you give blood - check:

- *Correct patient?* - **check** patient identity against notes and transfusion form
- *Correct blood?* - **check** label on blood and transfusion form

- *Correct group?* - **check** donor blood according to transfusion form

- *Correct date?* - **check** donor blood

### Using blood appropriately

As anaesthetists we can make an impact on clinical use of blood beyond the care of our own patients. However small our contribution, we can play an important part in creating the conditions in which the appropriate clinical use of blood is possible. While progress may initially be slow, a regular and systematic review of transfusion practices should demonstrate the effectiveness of change and point to areas where further improvement may be needed.

### Further reading

1. The Clinical Use of Blood in Medicine, Obstetrics, Paediatrics, Surgery and Anaesthesia, Trauma and Burns. World Health Organization Blood Transfusion Safety. Geneva. WHO/BTS/99.2 ISBN 92 154538 0
  2. Hebert PC, Wells G et al. A multicenter randomised controlled trial of transfusion requirements in critical care. *New England Journal of Medicine* 1999;**340**:409 - 417.
  3. Murphy MF, Wallington TB et al. British committee for standards in haematology, blood transfusion taskforce. Guidelines for the clinical use of red cell transfusions. *British Journal of Haematology* 2001;**113**:24-31
  4. British Committee for Standards in Haematology, blood transfusion task force. Guidelines for autologous transfusion. *Transfusion Medicine* 1993;**3**:307-316
  5. Napier JA, Bruce M, Chapman J et al. Guidelines for autologous transfusion II. Perioperative haemodilution and cell salvage. *British Journal of Anaesthesia* 1997;**78**:768 - 71.
-

## LEVOBUPIVACAINE

### *A long acting local anaesthetic, with less cardiac and neurotoxicity*

Manuel Galindo Arias, MD, Professor of Anesthesiology Fundacion Univarsitaria San Martin, Bogota, Colombia

#### Introduction

The property of isomerism occurs when two or more compounds have the same molecular composition, but a different structure which often results in different properties. There are two types of isomerism - structural and stereoisomersim.

Structural isomerism means that the compounds have the same molecular formula, but a different chemical structure. This may result in the compounds having similar actions like the anaesthetic volatile agents isoflurane and enflurane or different actions like promazine and promethazine.

Stereoisomerism describes those compounds which have the same molecular formula and chemical structure, but the atoms are orientated in a different direction. There are two isomers, each a mirror image of the other, called enantiomers. They are also called optical isomers because they rotate the plane of polarised light either to the right referred to as +, dextro, d or D isomer, or to the left referred to as -, laevo (levo), l or L isomer. More recently this classification has been replaced by the R-/S- notation, which describes the arrangement of the molecules around the chiral centre (R is for rectus the Latin for right, and S for sinister, left). The R enantiomer rotates light to the right and the S enantiomer to the left. As with other isomers, they can have different properties.

The molecule of bupivacaine, a long acting local anaesthetic, has an asymmetric carbon atom. For this reason, with this asymmetric carbon as a chiral centre, bupivacaine exhibits this phenomenon. In the commercial presentation of this local anaesthetic there is a 50:50 proportion: levobupivacaine, L (-) isomer, and dextrobupivacaine D (+) isomer. This preparation which contains both enantiomers is called a racemic mixture

The preparation of levobupivacaine contains only the levorotatory isomer present in the commercial preparations of bupivacaine.

Interest in levobupivacaine arose after several cases of severe cardiotoxicity (including death) were reported where it was shown that the D isomer of bupivacaine had a higher potential for toxicity. Consequently, it was thought that if it was possible to use only the levorotatory isomer, levobupivacaine, the risk for cardiac and neurotoxicity could be less than with the racemic bupivacaine but with similar clinical effects.

#### Chemistry

Here we will expose some general concepts about all local anaesthetics, with a special reference to levobupivacaine.

Local anaesthetic molecules all have three characteristic portions (figure 1):

- A benzene ring - aromatic head

- An intermediate chain

- An amino group

The benzene ring is very soluble in lipids.

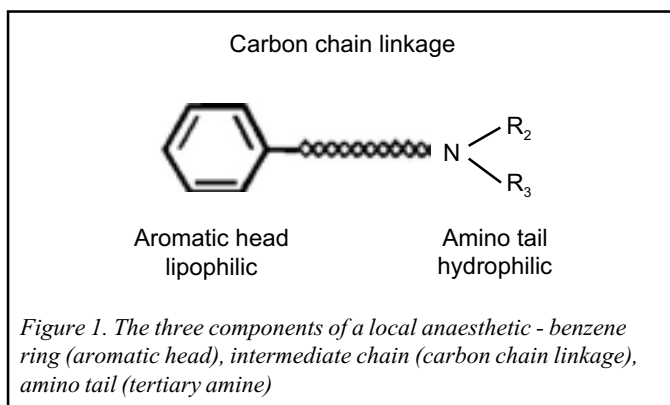

The intermediate portion, a bridge between the other two, can have one of two types of chemical structures: Ester (COO-), or Amide (CONH-) (figure 2). Therefore, chemically, there are two large groups of local anaesthetics, depending on this intermediate portion of the molecule: Ester type and Amide type local anaesthetics. Procaine is the prototype of the first group (figure 3), and lignocaine is the prototype of the second one (figure 4). The first group more commonly cause allergic reactions and have a short length of action as they are rapidly metabolized by cholinesterase. In contrast the second group, amides, rarely cause allergic reactions but are more likely to cause toxic reactions if the dose is exceeded. Levobupivacaine is an amide, which like the other amides, is a weak base.

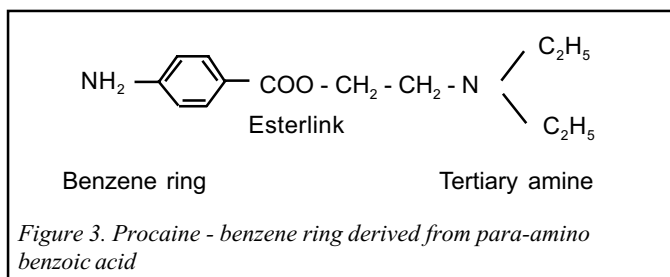
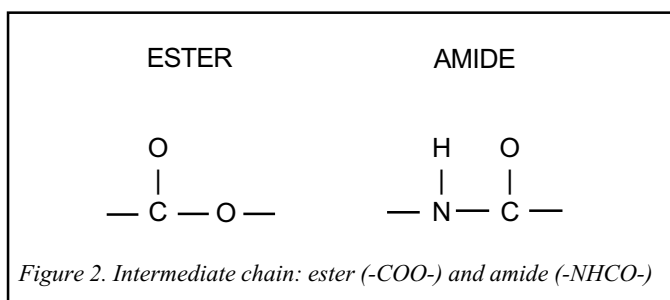

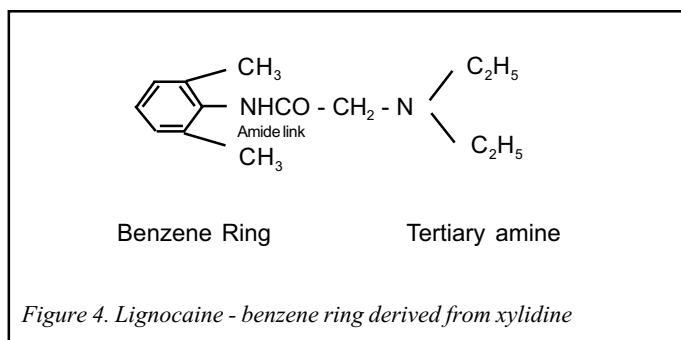

Depending on the pH, the amino group can adopt the tertiary or the quaternary form. The drug is in dynamic balance between the tertiary form, a free base, and the quaternary form, which has a positive charge, making it very water-soluble.

The pKa of levobupivacaine is 8.1, similar to the pKa of the racemic bupivacaine. (*pKa is the pH at which 50 % of the molecules are free base and 50 % of the molecules have a positive charge - ionised*)

If bicarbonate is added to levobupivacaine, the pH is increased leading to a rise in the percentage of free base molecules. Those molecules cross more easily through the axon membrane and the pharmacological action begins more quickly.

In contrast, if the pH is low (acid), as happens when there is a local infection, there will be less free base molecules to cross the axon membrane resulting in smaller action over the axon.

Protein binding of levobupivacaine is more than 97%, mainly to acid alpha1-glycoprotein, rather than to albumin. This union to proteins is somewhat higher than the union of racemic bupivacaine to proteins (95%). This means that less than 3% is free in plasma. It is the free levobupivacaine, a small fraction of the total concentration that can have an action on other tissues, causing the unwanted side-effects, and producing the toxic manifestations. In hypo-proteinaemic, undernourished patients, patients with the nephrotic syndrome and in the newborn there is less protein for binding, causing higher levels of free drug, resulting in toxic effects being seen at lower doses

Bupivacaine has stereoisometric properties as explained earlier. Commercial production of levobupivacaine for clinical use was started because it was observed experimentally that the D isomer had a lower threshold for causing tachycardia and dysrhythmias, which include, AV block, QRS widening and ventricular tachycardia and fibrillation than either the L isomer or the racemic preparation.

The levo isomer was used in rats and its effect was compared with the dextro isomer. It was found that with doses of 2mg/kg, all the animals of the dextro group developed apnoea, bradycardia, hypotension and finally died. In contrast, no animal in the levobupivacaine group had apnoea and only 30% had a slight bradycardia. In sheep experiments in which racemic bupivacaine was administered in toxic quantities, it was found that the concentration of the dextro isomer was higher in the myocardium and brain than the concentration of the levo isomer.

This work together with other similar studies, led the investigators to conclude that levobupivacaine was less toxic than the racemic bupivacaine, but with similar clinical activity. Additionally,

electrophysiological studies have been made which demonstrate that blockade of the inactive sodium channels is stereoselective, with the D isomer being more potent and faster than the L isomer. As this includes the cardiac fibres, it explains the higher cardiotoxicity associated with the D isomer.<sup>1</sup>

Some of the first clinical studies in humans in Brazil, compared the effects of the racemic preparation and the levo isomer of bupivacaine when given peridurally. No significant difference in onset time, quality of anaesthesia and level of blockade has been found.

### Pharmacokinetics

There are difficulties in carrying out pharmacokinetic studies with bupivacaine. Classic pharmacokinetic studies are usually performed using an intravenous application of the drug. These studies are more accurate because there are fewer possible causes of error, than when other access routes are used, such as intramuscular or subcutaneous infiltration. With both these routes of administration, the rate of absorption is an important but unknown factor affecting the rate of absorption between patients with different pathologies. In addition intravenous administration of bupivacaine or levobupivacaine, for pharmacokinetic studies has limitations, because of the risk of fatal toxicity. Additionally, in clinical practice this drug is not used intravenously.

Practical clinical studies have been carried out giving the drug for epidural and regional blocks. Placental transfer of levobupivacaine is similar to that of bupivacaine resulting in lower risk to the fetus. Like racemic bupivacaine, levobupivacaine is metabolised in the liver, primarily by the cytochrome P450, specially the CYP1A2 and CYP3A4 isoforms. Clearance is reduced when the hepatic function is damaged.

### Pharmacodynamics

The mechanism of action of levobupivacaine is exactly the same as that of racemic bupivacaine and that of all the local anesthetic drugs in clinical use today. When the minimum local analgesic concentration (MLAC) close to the membranes of the axons is reached, the molecules block the sodium channels, in the resting position. In this way, the transmission of the nerve impulses stops.

This action is produced with an onset very similar to that of racemic bupivacaine. The duration of action is also similar to that of the racemic substance.

Recent research work has been directed at the toxicity associated with the levo isomer, and how it compares with the racemic preparation. Differences were found between the two isomers. The concentration necessary to produce cardiac and neurotoxicity is higher for levobupivacaine than for racemic bupivacaine. The safety margin is estimated at 1.3 which means that toxic effects are not seen until the concentration rises by 30%

### Toxicity

Volunteers have been given bupivacaine or levobupivacaine intravenously at a rate of 10mg/min, until the appearance of early symptoms of central nervous system toxicity. These appeared at a lower dose (Mean 47.1mg) with bupivacaine than with levobupivacaine (56.1mg). Similarly there was a greater reduction in the myocardial ejection fraction and systolic and acceleration



index with racemic bupivacaine when compared to levobupivacaine. When 40mg of either levobupivacaine or racemic bupivacaine were administered over a 10min period, the EEG was significantly slower after racemic bupivacaine. Thus at similar doses, electrical activity is more affected by racemic bupivacaine.<sup>2</sup>

Levobupivacaine appears to cause less myocardial depression than both bupivacaine and ropivacaine, despite being in higher concentrations.

### Clinical Applications

Levobupivacaine has been introduced into clinical practice within the last few years. It has been used at all sites: epidural, subarachnoid, different levels of brachial plexus block - interscalene, supra and infraclavicular, intercostal and peripheral nerve blockade, peribulbar and retrobulbar blockade, local infiltration, obstetric analgesia, postoperative pain management, acute and chronic pain management. The doses used are very similar to those of bupivacaine. As a result of its lower cardiac and neurotoxicity compared to racemic bupivacaine, anaesthetists feel safer working with levobupivacaine, than with bupivacaine.

Nevertheless, we must always remember that it is still a potentially toxic local anaesthetic. The initial licensing authority recommended a maximum single dose of 2mg/kg, and 400mg (5.7mg/kg) in 24h. Since then, some studies have shown that higher doses are safe, but further work is required. Special caution is recommended for hypoproteinemic patients, including adults with nephrotic syndrome, severe hepatic disease and the newborn.

In Colombia, we have been using this new local anaesthetic for a year, with excellent results.<sup>3</sup> We only have the 0.75% formulation and use almost the same dose as when using bupivacaine. We have had no reports of toxic reactions. During the Colombian Congress of Anesthesiology (2001), a paper was presented, comparing levo-bupivacaine with ropivacaine in epidural anaesthesia. The two drugs were comparable, with a very good quality of epidural anaesthesia. However there were three cases of bradycardia in the levobupivacaine group which were treated successfully with atropine. The duration of the motor blockade in the postoperative period was less than after racemic bupivacaine.

### Adverse Effects

These are the same as caused by racemic bupivacaine and any other local anaesthetic. They include hypotension, bradycardia, nausea, vomiting, pruritus, headache, tinnitus, dizziness, constipation, vomiting and convulsions.

There have been reports of cases where the drug has been given in higher doses than that recommended, with no apparent toxicity.

In one case, a single dose of levobupivacaine of 250mg for a brachial plexus block, far exceeding the maximum recommended dose (150mg), without toxicity symptoms, although further data will be needed before the safety of this level of dosage is confirmed.

There is a report where approximately 1.7mg/kg racemic bupivacaine was injected probably by an accidental intravenous injection during an attempted supraclavicular brachial plexus block. The patient lost consciousness, developed a tachycardia, hypertension and generalized twitching, was managed with oxygen and propofol, with a successful recovery after a few minutes with no sequelae.<sup>4</sup> The authors stressed the risks associated with administration of high doses of bupivacaine, even in experienced hands and underline the need for possibly safer agents such as levobupivacaine.

### Conclusion

Levobupivacaine is a relatively new long acting local anaesthetic, with a pharmacological activity very similar to that of racemic bupivacaine. The first studies in humans confirm the animal studies and the in vitro studies, which showed that this new molecule is less cardiotoxic and less neurotoxic than the racemic bupivacaine. Levobupivacaine can be used for all indications in which the anaesthetist needs a long acting local anaesthetic. The reduced toxicity of this new local anaesthetic is an advantage for the patient. The cost in Colombia is 40% higher, than racemic bupivacaine.

### References

1. Tanelian DL. The new local anesthetics. Benefits, risk and use. Refresher Courses in Anesthesiology 1997;**25**:204-205
2. Bardsley H, Gristwood R, Baker H: A comparison of the cardiovascular effects of levobupivacaine and racemic bupivacaine following intravenous administration to healthy volunteers. British Journal of Clinical Pharmacology 1998;**46**:245-249
3. Martinez JC, Perilla C: Anestesia peridural para cirugía de miembro inferior. Comparación de levobupivacaina con ropivacaine. Revista Colombiana de Anestesiología (in press)
4. Cox CR, Checketts MR, MacKenzie N: Comparison of S(-) bupivacaine with racemic bupivacaine in supraclavicular brachial plexus block. British Journal of Anaesthesia 1998;**80**:594-8

### Further reading

McLeod GA, Burke D. Levobupivacaine. Anaesthesia 2001;**56**:331-341

## A MOBILE ANAESTHESIA SERVICE

Dr. Rico Rieder, Head of Department of Anaesthesia, Tansen Hospital, Nepal, [ricorieder@hotmail.com](mailto:ricorieder@hotmail.com)

Some of the more invasive procedures on the ward are painful and frightening for patients. This is particularly true in children who may be too young for local anaesthetic techniques alone. These patients are managed in a variety of ways in different hospitals but many require more analgesia than can be provided with parenteral morphine. Some hospitals take all such patients to theatre which has many advantages in terms of equipment and resources, others take equipment to a dedicated area of the routine ward.

Effective anaesthesia / sedation for procedures requires a combination of drugs that affect vital reflexes. To make the procedure as safe as possible, the patient needs to be directly supervised by someone with anaesthesia training and skills. This paper discusses our approach in Tansen, where we have developed a system which allows us to provide sufficient analgesia to perform small "ward-procedures" effectively.

### Indications

These include painful examinations, such as

- Lumbar punctures in children
- Dressing changes
- Manipulations
- Therapeutic as well as diagnostic procedures.

### Preparation

- The ward nurses prepares equipment normally kept on the ward. Extra equipment is brought by the anaesthetic nurse at the time of the procedure.

- Patient has to be fasted: 4 hours breast milk, 6 hours food, 2 hours clear fluid. Usually the procedure is performed in the morning, so patients can have their breakfast afterwards

### Procedure

At the arranged time the anaesthetist, anaesthesia nurse, patient and ward nurse are ready. After inducing the patient, the procedure is performed. The anaesthesia nurse stays with the patient until they are completely awake. Monitoring is by clinical observation, but a pulse oximeter is used whenever possible. The drugs most commonly used are 0.2mg/kg diazepam iv + 0.5-1mg/kg ketamine iv.

### Results

Over a 6 month period (April to September 2001) we anaesthetised 250 patients on the wards. The cost per procedure for the anaesthetic (including salaries, drugs etc.) was calculated with \$1, which made the service self-sustaining. No complications were encountered.

### Discussion

Ketamine, covered with diazepam (to prevent emergence reaction), can give adequate analgesia for painful procedures where local anaesthesia alone is inadequate or unsuitable. Essential anaesthetic precautions must be taken with an experienced anaesthesia practitioner. With careful attention to safety, the complication rate is very low (e.g. comparing with high doses of opiates), the analgesic effect is significantly better and the side effects reduced. There are also potential savings in theatre time.

<b>Ward nurse</b>	<ul style="list-style-type: none"> <li>● <i>airway and breathing</i> - oxygen, suction, self-inflating bag, anaesthetic masks, oro-pharyngeal airways, laryngoscope, endotracheal tubes, intubating stylet, tape</li> <li>● <i>intravenous</i> - cannulas and fluids, needles, syringes</li> <li>● <i>drugs</i> - adrenaline, atropine, lignocaine, diazepam, diclofenac, sterile water, sodium chloride</li> <li>● <i>various</i> - ampoule-cutter, tourniquet, syringes, sterile gloves</li> <li>● <i>tilting trolley</i> - if possible</li> </ul>
<b>Anaesthetic nurse</b>	<ul style="list-style-type: none"> <li>● <i>drugs</i> - ketamine, diazepam, suxamethonium (needs to be taken out of the fridge), atropine, ephedrine</li> </ul>

## ANAESTHESIA FOR CLEFT LIP AND PALATE SURGERY

R. C. Law and C. de Klerk - Royal Shrewsbury Hospital, Shrewsbury, U.K.

Cleft lip and palate are the commonest craniofacial abnormalities. A cleft lip, with or without a cleft palate, occurs in 1 in 600 live births. A cleft palate alone, is a separate entity and occurs in 1 in 2000 live births. Many complex classifications have been devised but essentially the cleft can involve the lip, alveolus (gum), hard palate and / or soft palate and can be complete or incomplete, unilateral or bilateral.

Embryologically, clefts arise because of failure of fusion or breakdown of fusion between the nasal and maxillary processes and the palatine shelves that form these structures at around 8 weeks of life. Without repair these children suffer from facial disfigurement and potentially social isolation, feeding problems and abnormal speech. Surgical repair of a cleft lip is usually undertaken at around 3 months of age for cosmetic reasons, although there is now a trend to do the operation in the neonatal period in Western countries. Correcting the defect early is popular with parents and facilitates bonding and feeding. The timing of cleft palate repair is a balance between poor facial growth with an early repair and poor speech development with a repair after the age of 1 year. It is usually done at about 6 months of age in developed countries. Cleft lips and palates are often done much later in less affluent countries.

For surgical repair of clefts to be performed safely requires a team approach. A surgeon wrote in 1912 that *'the difference to the surgeon, between doing a cleft palate operation with a thoroughly experienced anaesthetist and an inexperienced one, is the difference between pleasure and pain!'*<sup>1</sup> The majority of anaesthetic morbidity related to these procedures relates to the airway: either difficulty with intubation, inadvertent extubation during the procedure or postoperative airway obstruction. The optimum anaesthetic management will depend on the age of the patient, the availability of intraoperative monitoring equipment, anaesthetic drugs and expertise, and the level of postoperative care that is available.

### Preoperative evaluation

In addition to the standard preoperative history and examination special care needs to be taken in assessing the following:

- **Associated congenital abnormalities.** Cleft lip and palate is associated with about 150 different syndromes and therefore a thorough clinical examination should be made. The combination of a cleft palate, micrognathia and upper airway obstruction constitutes the Pierre-Robin Syndrome. Other common syndromes are the Goldenhar Syndrome and Treacher Collins Syndrome - table 1.
- **Congenital heart disease** occurs in 5 - 10% of these patients.
- **Chronic rhinorrhoea.** This is common in children presenting for cleft palate closure and is due to reflux into the nose during feeds. It needs to be distinguished from active infection that could require postponement of the surgery. Preoperative antibiotics for children with low grade nasal infections (positive nasal swabs) who are not unwell reduces the frequency of postoperative pyrexial illnesses.<sup>2</sup>
- **Chronic airway obstruction/sleep apnoea.** Parents of infants with cleft palates may give a history of snoring or obvious airway obstruction during sleep. These parents are often afraid to let the child sleep alone. A compromised airway may also present with apnoea during feeds, prolonged feeding time or failure to thrive due to an inability to coordinate feeding and breathing at the same time.
- **Right ventricular hypertrophy and cor pulmonale** may result from recurrent hypoxia due to airway obstruction. Even a primarily obstructive sleep apnoea syndrome normally has a central component to it (abnormality of central respiratory control). These children will therefore be very sensitive to any respiratory depressant effects of anaesthetic agents, benzodiazepines or opioid analgesics. Where available an ECG, echocardiogram and

Table 1:

Syndrome	Major features	Anaesthesia problems
Pierre Robin Syndrome	Cleft palate Small jaw Glossoptosis	Difficult intubation Chronic airway obstruction
Treacher Collins Syndrome	Small jaw and mouth Choanal atresia Ear and eye abnormalities	Airway and intubation difficulties (tend to get more difficult to intubate as they get older)
Goldenhar Syndrome	Hemifacial and mandibular hypoplasia Abnormalities of the cervical spine External ear and eye abnormalities	Airway and intubation difficulties (tend to get more difficult to intubate as they get older)

overnight saturation monitoring preoperatively will quantify the problem. However surgery is the treatment and most teams operate observing the child closely postoperatively, if possible in ICU.

- **Anticipated difficult intubation.** A difficult intubation is especially common in patients less than 6 months of age with either retrognathia (receding lower jaw) or bilateral clefts.<sup>3</sup>

- **Nutrition/hydration.** Because of potential difficulty with feeding, the state of hydration and overall growth needs to be assessed. A haemoglobin concentration should be checked and blood sent for cross matching although the need for transfusion is uncommon. There is a physiological decline in haemoglobin concentration after birth, which is at a maximum between 3 and 6 months of age. This is due to the change from fetal to adult haemoglobin. Nutritional anaemia is also common, especially in the developing world. Ideally all patients should have a haemoglobin concentration above 10g/dl. Clear fluids can be given up to two hours preoperatively and exclusively breast fed young infants can feed until four hours preoperatively.

- **Need for premedication.** Sedative premedication is not indicated in infants with cleft palates and should be avoided because of the risk of airway obstruction. Atropine may be prescribed to dry oral secretions and block vagal reflexes but the tachycardia produced makes it more difficult to assess anaesthetic depth and the intravascular volume status during the procedure. Anaesthetic techniques employing ether or ketamine or where particular difficulty with intubation is anticipated benefit from atropine premedication. A good rapport needs to be established with older children and parents.

### Intraoperative Management

Induction of anaesthesia is most safely performed by inhalational anaesthesia with halothane or sevoflurane. Intravenous access is gained when an adequate depth of anaesthesia is achieved and endotracheal intubation performed either under deep volatile anaesthesia or facilitated by suxamethonium or a non-depolarising neuromuscular blocking agent. **No neuromuscular blocking agents should be given until one is sure that the lungs can be ventilated with a mask.**

Endotracheal intubation may be difficult, especially in children with a craniofacial syndrome, and a variety of techniques such as blind nasal intubation, fiberoptic intubation, the use of bougies or retrograde techniques may need to be employed. An oral, preformed RAE tube is usually chosen and is taped in the midline. For palatal surgery, a mouth gag that fits over the tube is used to keep the mouth open and the tongue out of the way. The surgeon or anaesthetist will insert an oral pack to absorb blood and secretions and will extend the neck and tip the head down. A head ring and a roll under the shoulders is frequently used. Problems with the endotracheal tube are common. It may be pulled out, pushed into the right main bronchus when the head is moved or kinked under the mouth gag. After the patient has been finally positioned for surgery, check the patency and position of the endotracheal tube by auscultation and by gentle positive pressure ventilation to assess airway resistance.

Maintenance of anaesthesia with an inhalational agent can be with spontaneous ventilation or controlled ventilation. A

spontaneous breathing technique with halothane provides an element of safety in the event of accidental disconnection or extubation but is not suitable in very young infants.

Controlled ventilation with muscle paralysis allows for a lighter plane of anaesthesia and more rapid awakening with recovery of reflexes and the lower PaCO<sub>2</sub> probably causes less bleeding.

It is usual for the surgeon to inject local anaesthetic and adrenaline into the surgical field to reduce blood loss and improve the surgical field. It also provides some intraoperative analgesia. Limiting the dose of adrenaline to 5mcg/kg in the presence of normocapnia (can only be guaranteed if the patient is ventilated) and halothane is normally safe.<sup>4</sup>

Both palates and lips should either receive paracetamol 20mg/kg orally as premedication or rectal paracetamol post induction (40mg/kg) so that adequate paracetamol levels are attained by the end of surgery. Local anaesthetic infiltration provides useful intraoperative analgesia but cleft palates benefit from **careful** use of intraoperative opioids. Morphine sulphate 0.1-0.2mg/kg intravenously is commonly used and provides good early postoperative analgesia. The use of opioids results in a smoother emergence and less crying on extubation. This reduces trauma to the airway and decreases the risk of postoperative bleeding. A small dose of intraoperative morphine or fentanyl may be used for cleft lips but the attraction of bilateral infraorbital nerve blocks in this population is that they produce excellent intra- and postoperative analgesia and no respiratory depression. These nerve blocks are especially useful if a spontaneously breathing technique is used to repair cleft lips in young infants. Intraoperative and postoperative opioids are then not required (see inset for description of technique). NSAIDs, although very effective analgesics, may increase the risk of early postoperative bleeding. Their use should probably be delayed until at least twelve hours postoperatively. Anaesthetising a briskly bleeding cleft palate that has had to return to theatre can be a real challenge!

Although there is the potential for the blood loss to be significant enough to require blood transfusion, a better awareness of the risks of blood transfusion, especially the risks of transmission of infectious diseases has meant that this practice is less common than it used to be. The risks of transfusion need to be weighed against the expected benefits in every case. Blood transfusion of cleft lip repairs should be extremely uncommon but cleft palates will occasionally require blood transfusion.

Appropriate intravenous fluids should be given, taking into account the period of preoperative starvation, intraoperative and postoperative maintenance requirements and blood loss. Most surgeons allow early postoperative oral intake. Attention to temperature control is always important in paediatric patients but because of the extensive draping and little exposure during this operation, heat loss is rarely a problem.

### Extubation

Acute airway obstruction is a very real risk at the end of the procedure following extubation. The surgeon needs to remove the throat packs and ensure that the surgical field is dry. Suctioning should be kept to a minimum to avoid disrupting the surgical repair. Oropharyngeal airways are best avoided, if

possible. Extubation should be undertaken only after the return of consciousness with protective reflexes intact. A tongue stitch will often be placed in patients with preoperative airway obstruction. This pulls the tongue forward away from the posterior pharyngeal wall as a treatment for postoperative airway obstruction.

### Postoperative Management

These patients need to be closely observed in recovery for evidence of blood loss or airway obstruction and only returned to the ward when fully awake. Supplemental oxygen should be given until the child is fully awake and additional analgesia (intravenous morphine) can be carefully titrated to effect.

Postoperative analgesic regimes need to take into account where the child will be nursed. Cleft lips (especially those who received infraorbital nerve blocks) will only require rectal or oral preparations of paracetamol or NSAID's. Cleft palates should receive adequate doses of paracetamol and possibly oral codeine or NSAID's after twelve hours. **Ideally these patients should be returned to a high dependency area with experienced staff and oxygen saturation monitoring.** Only then is the administration of postoperative morphine for analgesia safe. A low dose morphine

infusion is the most predictable and titratable form of analgesia but is unlikely to be a safe option outside a specialist centre.

### Infraorbital Nerve Block

The infraorbital nerve is a terminal branch of the trigeminal nerve. It supplies sensory innervation to the skin and mucous membrane of the upper lip and lower eyelid, the skin between them and to the side of the nose. It can easily be blocked as it emerges from the infraorbital foramen, just medial to the buttress of the zygoma (bony prominence immediately lateral to the nose). In adults, the infraorbital foramen is in line with the supraorbital notch and mental foramen or the second upper premolar tooth. In neonates these landmarks are difficult to palpate or absent. Bosenberg performed an anatomical study on neonates that showed that the infraorbital nerve lies halfway between the midpoint of the palpebral fissure and the angle of the mouth, approximately 7.5 mm from the side of the nose.<sup>5</sup> The nerve is blocked by inserting a needle perpendicularly to the skin and advancing it until bony resistance is felt. The needle is then withdrawn slightly and 1-2mls of 0.5% bupivacaine and 1:200,000 adrenaline is injected after performing a negative aspiration test. The needle should not enter the infraorbital foramen.

## ALTERNATIVE ANAESTHETIC TECHNIQUES IN LESS AFFLUENT HOSPITALS

Dr Sarah Hodges, Kagando Hospital, Kasese, Uganda and Derriford Hospital, Plymouth, UK

In many countries, because of health service constraints, cleft lips and palates are not repaired as infants and many hospitals do not have oxygen and volatile anaesthetic agents. In these situations a very different approach to the anaesthetic management of these cases may be indicated. Airway management is of paramount importance and any surgical treatment requires an experienced surgeon and anaesthetist used to working in the local environment.<sup>6,7,8</sup>

Cleft lips in older children and adults can be repaired under local anaesthesia alone with good preoperative explanation and an experienced surgeon.<sup>8</sup> Intramuscular ketamine or intravenous boluses of ketamine with atropine can be used without intubation for a cleft lip repair in children over 12 months. This is only advisable if pulse oximetry is present and all equipment to intubate and ventilate is immediately available.

All patients undergoing cleft palate repair should be intubated. Techniques to maintain anaesthesia in this situation include volatile agents (halothane or ether) or total intravenous anaesthesia with ketamine and muscle relaxants. Either spontaneous or controlled ventilation have been used successfully, but it may be safer to ventilate or at least support ventilation in smaller children or those undergoing prolonged surgery<sup>6,8</sup>.

Small children and patients for a palate repair require careful attention to detail. If halothane and oxygen are both available then a gas induction is the safest method in all children for a cleft palate repair. Following induction and intubation, small children, particularly infants, are best ventilated by hand. Since capnography is rarely available, manual ventilation provides an excellent means of detecting any change in respiratory resistance.

This may occur if the endotracheal tube is occluded by the gag, displaced, disconnected, or blocked by sputum. Non-depolarising relaxants allow IPPV with a light plane of anaesthesia and rapid awakening. If necessary however, small children and infants can usually be ventilated without muscle relaxants. Intermittent boluses of suxamethonium can be used although care must be taken that the total dose does not exceed 8mg/kg body weight for the entire procedure.

If ether is the only volatile agent available, then an inhalational induction is extremely difficult and time consuming. Intramuscular ketamine and atropine provide an alternative. Airway reflexes are preserved and there is time to obtain intravenous access. If a difficult intubation is suspected or muscle relaxants are not available, ether can then be introduced and the patient deepened until the child can be intubated. This procedure requires time, expertise and patience. The alternative is to attempt to hand ventilate after ketamine anaesthesia is established and if this can be done easily, suxamethonium can be given to facilitate intubation.

Intraoperative and postoperative analgesia can be provided with infiltration of local anaesthetic and adrenaline directly into the surgical field or with the use of infraorbital blocks and regular paracetamol syrup on the ward postoperatively. If patients are nursed on large over-crowded, understaffed wards then opioids are best avoided. In view of the high incidence of postoperative airway complications it is safer to recover the patients in or adjacent to the operating theatre until they are fully awake.

Postoperative care facilities vary widely and it is crucial that adequate provision is made including trained staff, suction, airway equipment in a well lit environment

With a knowledge of the potential pitfalls and careful case selection safe anaesthesia can usually be provided by those with experience of working in difficult circumstances for these challenging cases.

## References

1. Gordon Jones R. A short history of anaesthesia for hare-lip and palate repair. *British Journal of Anaesthesia* 1971; **43**: 796.
2. Doyle E, Hudson I. Anaesthesia for primary repair of cleft lip and cleft palate: a review of 244 procedures. *Paediatric Anaesthesia* 1992; **2**: 139-145.
3. Gunawardana RH. Difficult laryngoscopy in cleft lip and palate surgery. *British Journal of Anaesthesia* 1996; **76**: 757-759.
4. Tremlett M. Anaesthesia for paediatric plastic reconstructive surgery. *Current Anaesthesia and Critical Care* 1996; **7**: 2-8.
5. Bosenberg AT, Kimble FW. Infraorbital nerve block in neonates for cleft lip repair: anatomical study and clinical application. *British Journal of Anaesthesia* 1995; **74**: 506-508
6. Ishizawa Y, Handa Y, Tanaka K, Taki K. General anaesthesia for cleft lip and palate surgery team activities in Cambodia. *Tropical Doctor* 1997; **27**: 153-155.
7. Ward CM, James I. Surgery of 346 patients with unoperated cleft lip and palate in Sri Lanka. *Cleft Palate Journal* 1990; **27**: 11-15.
8. Hodges SC, Hodges AM. A protocol for safe anaesthesia for cleft lip and palate surgery in developing countries. *Anaesthesia* 2000; **55**: 436-441.

## VIRTUAL ANESTHESIA MACHINE

Sem Lampotang, Ph.D. Department of Anesthesiology University of Florida Gainesville, Florida

The Virtual Anesthesia Machine (VAM) is a free, interactive, real-time computer animation of a two-dimensional representation of a generic anesthesia machine that can be viewed on a Windows or Macintosh personal computer.

The VAM simulates the gas flows, pressures and volumes in a "generic" anesthesia machine. Gas molecules ( $O_2$ ,  $N_2O$ , air,  $CO_2$ ) are not only made visible but are also color-coded to assist comprehension. The user can interact in real-time with the animation and set more than 15 anesthesia machine controls like the APL valve (adjustable pressure limiting), ventilation selector

knob,  $O_2$  and  $N_2O$  flow control valves, scavenging vacuum adjustment valve, tidal volume, respiratory rate, I:E ratio and inspiratory pause settings by clicking upon the corresponding icon with a mouse. Subsequently, the user can observe in real time the consequences of his or her action on lung, bellows, manual bag and scavenging bag volumes as well as inspired gas composition. The operation and function of safety features like the " $O_2$  failsafe" (cuts off the  $N_2O$  supply if  $O_2$  supply pressure fails) and the "hypoxic guard" (prevents dialing an  $FiO_2$  less than 0.25 with the flow meter control knobs) are clearly illustrated. The patient can be manually ventilated by "squeezing" the manual bag with a mouse click.

The absorption of  $CO_2$  in the soda lime canister and the influence of fresh gas flow,  $O_2$  flush and minute ventilation on the wash-in and washout of gases and vapors from different parts of the system, are also demonstrated. Gas and agent molecules are phased in and out in a realistic manner. The interactions between the pipeline and cylinder gas supplies are also depicted as well as the effect of a bellows tear.

In addition to the animation, tutorials about the anesthesia machine and the US Food and Drug Administration (FDA) 1993 recommendations for an anesthesia machine pre-use check are included. There are also instructions about how to use the VAM animation on the VAM web site, although it has a pretty intuitive user interface. The user simply clicks on any icon for the anesthesia machine control or component that he or she

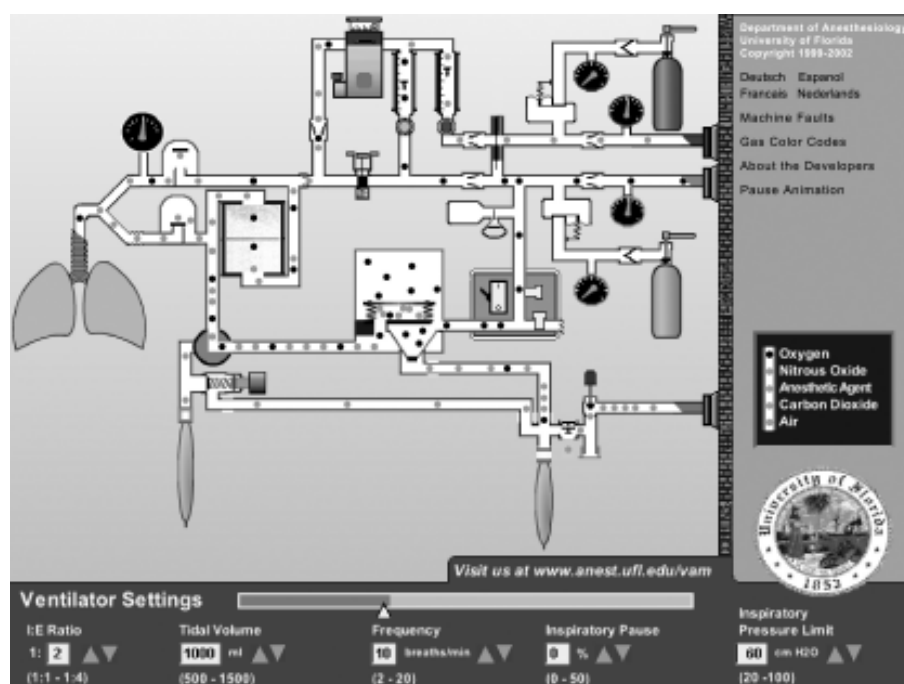

wishes to set. When the cursor is placed on an icon, the actual photograph of the component represented by the icon appears in a photo box to assist the user in identifying the icon and its function.

The VAM computer simulation is provided as a free service of the University of Florida Department of Anesthesiology to the global anesthesia community. VAM was awarded the American Society of Anesthesiologists (ASA) prize for the "Best Scientific and Educational Exhibit" and the Ellison C. Pierce award bestowed by the Anesthesia Patient Safety Foundation to the "Best Scientific Exhibit for Patient Safety" at the recent annual meeting of the ASA in New Orleans.

VAM can be downloaded via the Internet at <http://www.anest.ufl.edu/vam> and used without charge worldwide 24 hours a day, 7 days per week. VAM will require the free Macromedia Shockwave plug-in. If the latest version of the Shockwave plug-in is not already installed on your PC, you will

be automatically prompted to download it. An Internet connection is no longer required after the program has been downloaded which may take 5 - 10 minutes on a dial-up modem from a home PC. For users who may wish to teach with VAM at locations where there is no Internet access, a solution is to download the program to a notebook or portable PC. Once the animation is downloaded and running, disconnect the Internet connection and transport the notebook to the desired teaching location while leaving the PC powered on and the browser running.

VAM is best viewed using the Microsoft Explorer or Netscape web browsers on a PC with a clock speed of at least 300 MHz and a 1024 x 768 monitor. If you have any questions, problems, comments or suggestions, please contact me at [sem@anest4.anest.ufl.edu](mailto:sem@anest4.anest.ufl.edu). If you find the VAM web site useful, we encourage you to set a link to it from your institutional or personal web sites. Thank you.

## EXTRACTS FROM THE JOURNALS

Dr Henk Haisma, University Hospital Groningen, POBox 30001, 9700 RB Groningen, the Netherlands, presently queen Elizabeth Hospital, Blantyre, Malawi.

### Mechanical Ventilation in Acute Lung Injury (ALI) and Acute Respiratory Distress Syndrome (ARDS)<sup>1</sup>

ARDS develops in 25% of patients with sepsis, and in 8.7% of mechanically ventilated patients. Mortality in patients with ARDS is approximately 35% although death is usually due to multiple organ failure rather than to pulmonary failure.

There is increasing clinical and experimental evidence that poor ventilatory technique is harmful to the lungs. Ventilator induced lung injury (VILI) is thought to be caused by the application of physiological tidal volumes to the area of nonconsolidated alveoli. Delivering standard tidal volumes of 10-12ml/kg inevitably causes over-distension of these alveoli. Only tidal volume limitation has been shown to improve survival in a randomised controlled trial<sup>2</sup>. Similarly, repeated opening and closing of alveoli during ventilation may exert substantial damaging shear forces on epithelial cells. All this evidence has stimulated the development of so-called protective strategies for mechanical ventilation that minimise further damage to the lung<sup>3</sup>.

Protective strategies include:

- **Inspired oxygen concentration** - ventilation using high concentrations of inspired oxygen rapidly causes absorption atelectasis and possibly pulmonary cytotoxicity. Standard practice is to titrate the FIO<sub>2</sub> to an arterial oxygen saturation of 90%. However, patients who are treated with low tidal volumes will require a higher FIO<sub>2</sub> (0.56% versus 0.51%<sup>2</sup>) compared with those receiving traditional tidal volumes.

- **End-inspiratory volume/pressure.** In patients with ARDS mechanical ventilation with a lower tidal volume than is traditionally used, results in decreased mortality and increases the number of days without ventilator use. Therefore, standard practice in these severely ill patients should be to ventilate them with a tidal volume of 6 ml/kg and end-inspiratory pressures around 25cmH<sub>2</sub>O. To accomplish a sufficient arterial oxygen saturation, respiratory rate has to be increased. These low tidal volumes may compromise alveolar ventilation and result in "permissive" hypercapnia, but this is generally felt to be preferable to worsening lung damage as long as the patient is not significantly acidotic, i.e. pH maintained >7.25. Disadvantages include raised intracranial pressure, impaired myocardial contractility and increased requirement for sedation.

- **End-expiratory volume/pressure.** Positive End Expiratory Pressure (PEEP) can prevent cyclic collapse and opening of alveoli hence preventing the generation of high shear forces across the alveolar epithelium (open lung theory). Unfortunately PEEP can also cause circulatory depression and may increase risks of barotrauma. The optimal level of PEEP to limit VILI is still under debate. Most clinicians have apparently adopted the approach to use the least PEEP necessary to achieve satisfactory arterial oxygenation with a limited inspired oxygen concentration. Lower tidal ventilation in general requires a higher PEEP<sup>2</sup>: 9.4 versus 8.6). Continuous maintenance of PEEP is vital, because a single breath without PEEP may result in alveolar collapse.

● **Mode of ventilation.** In Pressure Control Ventilation (PCV) a target inspiratory airway pressure can be selected preventing stretch induced lung injury. The resulting tidal volume depends on the compliance and resistance of the respiratory system. A deterioration in airways resistance or compliance, or a short inspiration, reduce tidal volume during PCV. A resulting drop in alveolar ventilation may cause severe hypercapnia and acidosis. In Inverse Ratio Ventilation (IRV) the duration of inspiration is extended and the duration of expiration is shortened. Arterial oxygenation improves by recruiting lung and reducing shunt but also through increasing mean airway pressure. The reduction in the expiratory time can cause hyperinflation (auto-PEEP). A reduction in respiratory rate allows prolongation of expiratory time but at the expense of alveolar ventilation.

● **Prone position.** Prone position is known to rapidly improve oxygenation in patients with ARDS due to improved regional ventilation and so reducing shunt. It has not yet been shown to improve survival.

Some very innovative technologies for supporting gas exchange in ALI and ARDS, such as partial liquid ventilation and high-frequency ventilation have yielded disappointing results in carefully conducted clinical trials, will require substantial investments by hospitals and can therefore not be recommended until improved outcome has been demonstrated.

1. Brower RG, Fressler HE. Mechanical ventilation in acute lung injury and acute respiratory distress syndrome. *Clinics in Chest Medicine* 2000;**21**:491-510
2. The Acute Respiratory Distress Syndrome Network. Ventilation with lower tidal volumes as compared with traditional tidal volumes for acute lung injury and the acute respiratory distress syndrome. *New England Journal of Medicine* 2000; **342**:1301-1308.
3. Finney JF, Evans TW. Mechanical ventilation in acute respiratory distress syndrome. *Current Opinion in Anaesthesiology* **14**:165-171

## Haemodynamic Management of a Patient with Septic Shock<sup>1</sup>

Haemodynamic support in patients with septic shock aims to maintain perfusion of vital organs with oxygenated blood. In almost all patients with septic shock, adequate volume loading is likely to be the first and probably the most important step in supportive therapy. There are still no definitive prospective studies with respect to the best choice between crystalloid and colloid for restoring the intravascular volume. The adequacy of volume loading seems to be more important than the type of fluid used.<sup>2</sup> The decrease in haemoglobin concentration to 7-9g/dl is well tolerated by many patients, because the induced reduction in blood viscosity may reduce cardiac afterload, and the increased venous return may enhance cardiac output.

Treatment with vasopressors (norepinephrine = noradrenaline) is often indispensable in the therapeutic management of patients with septic shock. As long as the global oxygen supply is in the supranormal range, treatment with norepinephrine alone seems to be without negative effects on tissue oxygenation. Deterioration of tissue oxygenation may occur following the administration of epinephrine (adrenaline), pointing out the limited role for epinephrine in the treatment of septic patients.

When dobutamine is used to increase oxygen delivery, there is some evidence of improvement in tissue oxygenation. However, Hayes et al.<sup>3</sup> found no difference in global oxygen consumption between patients treated with dobutamine and those who were treated only with adequate volume therapy. Surprisingly, survival in the patients with the dobutamine treatment was lower than in the control group. There is some evidence that low dose dobutamine may maintain better splanchnic oxygenation in patients on high doses of norepinephrine.

It remains questionable whether the management of septic shock with high doses of dopamine alone is superior to the combination of dobutamine and norepinephrine. It is doubtful that low dose dopamine can prevent renal failure, and there is evidence that low-dose dopamine has deleterious effects on splanchnic oxygenation.

Summary of the most important steps in supportive treatment of sepsis<sup>1</sup>

- Find and treat the septic source
- Surgical therapy, removal of iv lines, antibiotics
- Maintain adequate volume status
- Fluid resuscitation guided by parameters of global haemodynamics (peripheral temperature, CVP) and organ function (like urine output.)
- Maintain adequate oxygen delivery
- Early intubation and ventilation, low dose dobutamine
- Maintain an adequate perfusion
- Norepinephrine

*see also Update in Anaesthesia Number 13 - The Management of Septic Shock*

1. Reinhard K, Sakka SG, Meier-Hellmann A.: Haemodynamic management of a patient with septic shock. *European Journal of Anaesthesiology* 2000;**17**: 6-17
2. Schierhout G, Roberts I. Fluid resuscitation with colloid or crystalloid solutions in critically ill patients: a systemic review of randomised trials. *British Medical Journal* 1998;**316**:961-964
3. Hayes MA et al. Elevation of systemic oxygen delivery in the treatment of critically ill patients. *New England Journal of Medicine* 1994;**330**:1717-1722



## LETTER TO THE EDITOR

Karl Eckhardt, M.D., St. Mary Medical Center, Walla, Washington, USA

Samuel Aseno, M.D., Director, International Anaesthesia Training Centre, Kilimanjaro Christian Medical Centre, Moshi, Tanzania

### The Individually Fitted Earpiece

Sir,

There is world wide agreement that ventilation and circulation of the anaesthetised patient must be monitored. The ideal situation of continuous monitoring is, indeed, difficult to achieve without electronic aids such as oximetry and capnography. However, the continuous auscultation of breath sounds and heart sounds is greatly underutilised as a technique of monitoring cardiopulmonary performance. It has several advantages over the more sophisticated and vastly more expensive electronic monitors. It is simple, mechanical (does not require electricity), cannot break, and does not need maintenance.

*Why is auscultation not used more often?* The use of a normal stethoscope for more than a few minutes becomes painful! This obstacle can be overcome by the use of an earpiece which is custom made for the individual anaesthetist's ear. This allows the continuous use of a monaural (single ear) stethoscope with no discomfort. Making this earpiece does require the use of some technical skills, but the materials are readily available, and anyone with the skills necessary to make a set of dentures can make the finished earpiece.

An important advantage of the monaural stethoscope is that it leaves the other ear free to listen to the other sounds in theatre that should be observed: communication with the surgeon and other theatre personnel; the suction; any other monitor or alarm sounds that exist.

The earpiece may be connected to a stethoscope in a number of ways. The esophageal stethoscope is a remarkably loud and clear source of heart and breath sounds. Michael Dobson<sup>1</sup> describes a very simple and effective method of making an esophageal stethoscope using a nasogastric tube and the finger of a rubber glove. Commercially available ones are relatively cheap and sturdy



Figure 1. A single ear stethoscope in use

enough so that, with proper cleaning, they can be reused many times. In situations where Doppler monitoring is not available, the esophageal stethoscope will be the best means of early detection of venous air embolism. Also the esophageal stethoscope can do a few things that electronic monitoring cannot: detect the onset of wheezing and identify secretions that need to be removed by suction. In



Figure 2. Positioned for monitoring breath sounds during ketamine anaesthesia

small children a stethoscope over the heart is an effective monitor of both breath and heart sounds.

Auscultation of air exchange by taping a stethoscope over the trachea can dramatically improve both the detection and correction of soft tissue airway obstruction in the patient breathing spontaneously without an endotracheal tube in place. Manipulations which improve the airway will be readily detectable.

The monaural stethoscope may be placed over the brachial artery and used for measuring blood pressure. A 3-way tap can be used to link and quickly change the connection of the earpiece between 2 stethoscopes (one over the artery and the other used for listening to breath and heart sounds).

An individually fitted earpiece begins with making an impression of the ear canal. As one normally holds the mask with the left hand and operates the reservoir bag with the right hand, the body is angled so that the left ear faces the surgical field more than the right. It may be easier to hear the sounds in the room if that left ear remains unobstructed and the right ear selected for the stethoscope. After checking the meatus is clear, a foam ear canal blocker is placed about midway in the ear canal. The impression resin is mixed and injected in one continuous stream. The person making the mold and then the final earpiece will most likely be someone with skills similar to a dental technician who makes plastic dentures. In large cities, a hearing aid laboratory can easily perform this job.

### Reference

1. Anaesthesia in the District Hospital. World Health Organisation 2001

## CASE REPORT - TOTAL SPINAL ANAESTHESIA

L.M. Dijkema and H.J. Haisma, Department of Anesthesiology, University Hospital Groningen, P.O.Box 30001, 9700 RB Groningen, the Netherlands., e-mail:[l.m.dijkema@anest.azg.nl](mailto:l.m.dijkema@anest.azg.nl)

This is a report of a patient who suffered an unexpected high level of block during spinal anaesthesia. This review will describe the symptoms, predictive factors and the management of a “total spinal”.

### Case Report

A 35-year old primigravida was scheduled for caesarean section because of expected difficult delivery due to a narrow pelvis. She had no relevant medical history. Her height was 1.58m. and she weighed 85kg. After discussion with the patient spinal anaesthesia was planned.

In the theatre electrocardiography, blood pressure monitoring, pulse oximetry and peripheral venous access were established and 500ml of normal saline was given. The spinal anaesthesia was performed in the sitting position at L4/L5 with 2.4ml. bupivacaine 0.5% in hyperbaric dextrose solution - “*Heavy Marcaine*”. Immediately following the block the patient was put back in the supine position, and the operating table altered with left lateral tilt to diminish aorto-caval compression.

About 5 minutes later the patient complained of nausea and “not feeling well” and experienced progressive difficulty to breathe. The blood pressure fell to 65/40mmHg.

### Definition of total spinal

● Total spinal is a local anaesthetic depression of the cervical spinal cord and the brainstem. It may follow excessive spread of an intrathecal injection of local anaesthetic, or inadvertent spinal injection of an epidural dose of local anaesthetic.

### Predicting factors

Spread of block is influenced by many factors:

- **Local anaesthetic dose** - volume, dosage and baricity of local anaesthetic.
- **Position of the patient** - especially important when a hyperbaric solution of local anaesthetic is used.
- **Patient characteristics** - height, age, gender, intra-abdominal pressure and anatomical configuration of the spinal cord.
- **Technique** - type of needle, site of injection, direction of needle, velocity of injection and use of barbotage.

The patient in our case was a pregnant woman. Pregnant women have a raised intra-abdominal pressure and a diminished volume of the lumbar spinal canal caused by distension of the epidural veins. We therefore gave her a reduced dose of local anaesthetic (2.4ml bupivacaine 0.5% hyperbaric).

The spread of spinal block is sometimes very rapid. The level of the block should be tested within 4 minutes after the injection of local anaesthetic. Commonly used methods of assessing the block are: loss of temperature sensation, loss of pinprick sensation and

loss of light touch sensation. Temperature sensation is lost first and light touch sensation last. A block may continue to extend for at least 30 minutes after injection.

### Clinical symptoms

Early recognition is the key to management in case of total spinal.

● The first signs of high spinal block are hypotension, bradycardia and difficulty in breathing. Before hypotension is detected, the patient often complains of nausea or “*not feeling well*”. Tingling in the fingers indicates a high block at the level of T1 (occasionally anxious patients who are hyperventilating may complain of this).

● Hypotension is due to venous and arterial vasodilation resulting in a reduced venous return, cardiac output and systemic vascular resistance. It should be treated with volume infusion and vasopressors. The head-down (Trendelenburg) position should be used with caution because it may raise further the level of blockade. A better alternative is to raise the legs.

● Bradycardia is caused by several factors. Extensive spread results in a widespread sympathetic block leading to unopposed vagal tone and blockade of the cardio-accelerator fibres arising from T1-T4. Heart rate may also decrease as a result of a fall in right atrial filling. Bradycardia can be treated with anticholinergic agents, like atropine, or  $\beta$ -adrenergic agonists, like ephedrine.

● Cardiac output is the product of heart rate and stroke volume. As we have seen, heart rate and stroke volume decrease. The most important reason for the decrease in stroke volume is the decreased volume of blood in the ventricle at the end of diastole (end-diastolic volume), often called “preload”. This is due to a reduction in venous return because of marked venous dilatation following spinal anaesthesia and compression of the vena cava by the pregnant uterus. Venous return is reduced further, if the patient is ventilated, due to the increase in intra-thoracic pressure during the inspiratory phase. Any bleeding which reduces blood volume is poorly tolerated, (*see Cardiovascular Physiology and also the Pharmacology of Inotropes and Vasopressors in Update in Anaesthesia No 10*).

● Respiratory difficulty is caused by loss of chest wall sensation caused by paralysis of the intercostal muscles. Patients often describe their breathing as feeling abnormal, but can demonstrate a good inspiration and can cough and speak normally. When a total spinal occurs the nerve supply to the diaphragm (cervical roots 3-5) is blocked and respiratory failure develops rapidly. Early warning signs include poor respiratory effort, whispering and an inability to cough. Sudden respiratory arrest is usually caused by hypoperfusion of the respiratory centres in the brainstem.

● Cardiac arrest may occur due to hypotension and hypoxaemia. Prevent this by adequate ventilation and use of vasopressors.

- Other symptoms of total spinal are upper extremity weakness, loss of consciousness and pupillary dilatation.
- Pregnant patients in this situation are at risk of aspiration and severe reductions in placental blood flow.

### Management

Our patient was immediately treated with 100% oxygen by mask, volume infusion and ephedrine. However she remained hypotensive despite a total of 30mg ephedrine IV and her condition continued to deteriorate. A rapid sequence induction was performed with thiopentone (100mg) and succinylcholine (100mg) and mechanical ventilation was started. After further volume loading with 1500mls crystalloid and 500mls of colloid solution she became haemodynamically stable without the further use of vasopressors. Anaesthesia was continued using isoflurane 0.6 % and nitrous oxide in oxygen (50/50%). A baby boy was born who had a good Apgar scores (7-9-10 after 1-5-10 minutes). Our patient was mechanically ventilated during 30 minutes in the recovery room under propofol sedation until her breathing pattern had normalized. When she was fully awake we explained her what had happened.

### Treatment of a total spinal

- A total spinal has to be treated symptomatically. Oxygen and intravenous vasopressors (ephedrine 5-10mg or metaraminol 1-2mg, and if necessary adrenaline 50-100microgram (0.5 - 1ml of 1:10,000 solution) will always be needed. If the airway and breathing are satisfactory, the patient should be given oxygen and the blood pressure restored with vasopressors and intravenous fluid.
- If the patient experiences progressive difficulty in breathing and speaking, the level of block is around C3-C5, the patient should be gently ventilated and the airway secured. Cricoid pressure should be used if practical.

- If apnoea develops, ventilation should be started immediately and the patient intubated. In this case we used thiopentone because it was immediately available. Some anaesthetists prefer a less cardiovascularly depressant agent like etomidate or ketamine, but a small dose of thiopentone is also safe. When the patient has been intubated and mechanically ventilated it is important to sedate the patient until they can breathe effectively.

### Outcome

The patient in our case recovered without harm and also the baby suffered no ill effects. The outcome of a total spinal is good when it is recognised early and treated effectively. All the clinical problems associated with a high spinal will reverse when cardiovascular and respiratory support are provided. After some time the level of the block will recede and wear off. It is important to start treatment immediately to prevent damage and harm to the patient. Afterwards explain to the patient and family what happened because a total spinal can be a very frightening experience.

The length of time that the block will last depends on the dose of local anaesthetic injected. With a spinal anaesthetic which spreads unexpectedly high, the block should start to recede after 1 - 2 hours. After a total spinal due to an epidural injection being delivered into the intrathecal space (subarachnoid or spinal) the block may last several hours due to the increased amounts of local anaesthetic injected. During the whole time of the high block the patient will need to be ventilated, if necessary by hand, until the anaesthetic wears off. Since the patient will recover consciousness before being able to breathe effectively some sedation (diazepam, midazolam or propofol) will be useful. Indications for extubation will include a good cough reflex on the endotracheal tube and effective spontaneous respiratory effort.

## SELF ASSESSMENT SECTION

Chris Sweeting, Royal Devon and Exeter Hospital, Exeter, UK

Rob Law, Royal Shrewsbury Hospital, Shrewsbury, UK.

### Multiple Choice Questions

1. *Drugs that block beta-adrenergic receptors (i.e. "beta-blockers") can produce:*
  - a. Bradycardia
  - b. Asthma
  - c. Cold hands
  - d. Angina
  - e. Lethargy
2. *The following are normal values for a 3 year old child:*
  - a. Systolic blood pressure of 85mmHg
  - b. Respiratory tidal volume of 160ml
  - c. Pulse rate of 60 beats per minute
  - d. Respiratory rate of 10 breaths per minute
  - e. Circulating blood volume of 1.1 litres
3. *In children:*
  - a. The larynx is at a lower level than in an adult
  - b. The epiglottis is relatively large and floppy when compared to that of an adult
  - c. The narrowest part of the airway is at the cords
  - d. The larynx is less susceptible to oedema
  - e. Laryngospasm is more likely
4. *Volatile anaesthetic agents:*
  - a. Recovery is faster with agents with a high solubility in blood
  - b. Gaseous induction is slowed in high cardiac output states
  - c. More volatile is needed following an increase in inspired oxygen
  - d. Volatile anaesthetics all produce good analgesia
  - e. 50% of patients will move on skin incision with 1MAC of volatile agent
5. *Gastric emptying is slowed:*
  - a. In trauma
  - b. By opioids
  - c. By alcohol
  - d. In the first trimester of pregnancy
  - e. With hypothermia
6. *The cerebral blood flow (CBF) of a normal person is increased:*
  - a. If the intracranial pressure is increased
  - b. With administration of ketamine
  - c. If the mean arterial blood pressure rises from 90 to 110mmHg
  - d. When the arterial CO<sub>2</sub> increases
  - e. When placed in the head-down position
7. *Sympathetic stimulation may result in:*
  - a. An increased heart rate
  - b. An increase in myocardial contractility
  - c. An increase in skeletal muscle blood flow
  - d. An increase in cardiac output
  - e. Arrhythmias during halothane anaesthesia
8. *The height of a spinal block can be affected by:*
  - a. Local anaesthetic dose
  - b. Height of patient
  - c. Local anaesthetic baricity
  - d. The interspace used for the spinal injection
  - e. The addition of adrenaline to the local anaesthetic
9. *Characteristic features of cardiac tamponade include:*
  - a. Raised JVP
  - b. Tachycardia
  - c. Tracheal deviation
  - d. Hypotension
  - e. A fall in JVP on inspiration
10. *Suxamethonium*
  - a. Is effective when mixed with thiopentone
  - b. Muscle relaxation always wears off quickly following a single dose
  - c. Muscle relaxation always wears off quickly following multiple doses
  - d. Post suxamethonium muscle pains are worst in young adults
  - e. Causes arrhythmias

### Clinical Scenario 1

A 32 year old woman presents with a three day history of central abdominal pain of increasing severity. She had an appendicectomy when aged 17, but otherwise has been fit and well. She has a respiratory rate of 30, pulse rate of 135 and a blood pressure of 90 / 55, and she feels hot and sweaty. Her abdomen is rigid with guarding, and a laparotomy is planned. Her Hb is 15.2, white cell count 17,000 and platelets 353 x10<sup>9</sup>. Na<sup>+</sup> 145mmol/L, K<sup>+</sup> 5.2mmol/L, Creatinine 190 micromol/L and urea 12mmol/L.

### Question - how would you assess and manage this patient prior to theatre?

The clinical signs suggest that this patient is shocked. Sepsis would be the most likely cause, unless she had taken a toxic substance. Her blood results are all consistent with severe fluid depletion and the raised creatinine and urea rising indicate developing acute renal failure. The raised WCC supports the diagnosis of sepsis.

One should look for signs of poor organ perfusion such as oliguria, confusion, cool peripheries or a metabolic acidosis on arterial blood gas analysis. Initial treatment should involve face mask oxygen, intravenous fluid resuscitation and appropriate analgesia. The patient should be catheterised and urine output accurately measured. If available blood should be taken for a coagulation screen and a chest Xray performed if the patient is hypoxic or has clinical signs on auscultation.

The patient will require several litres of intravenous fluid (0.9% saline or equivalent) prior to going to theatre. If observations do not improve with intravenous filling then a central venous line may help assess how much intravenous fluid is appropriate. Commence broad intravenous antibiotic cover.

Following rapid sequence induction of general anaesthesia, surgery reveals adhesions and a perforated small bowel, with widespread faecal contamination of the peritoneum. Her blood pressure has fallen to 70 / 35, with a pulse rate of 155.

### **Question - how do you treat this blood pressure?**

Hypovolaemia and sepsis are the most likely causes and a CVP line should be inserted. Give further fluid if her central venous pressure is low, or only transiently rises with fluids. Other treatable causes of hypotension should be excluded (excessive anaesthetic, tension pneumothorax, anaphylaxis, cardiac arrhythmias, ischaemia or tamponade, pulmonary embolism, hypothermia, gross electrolyte, acid base or glucose abnormalities).

In sepsis, hypotension is often not treatable by fluid resuscitation alone and inotropic support should be commenced. Understanding the pathophysiology of septic shock is helpful when choosing an appropriate inotrope. In sepsis, the infecting organisms release toxins into the blood stream, and the patient produces mediators such as cytokines and complement, all of which have systemic effects (see *Update in Anaesthesia No 13*). The cardiovascular effects include depression of contractility, vasodilatation, maldistribution of blood flow and damage to the endothelium (the lining of blood vessels). This results in a decrease in systemic vascular resistance and organ dysfunction and may lead to refractory hypotension, multiple organ failure and death. The hypotension is mainly due to a low systemic vascular resistance, and in 90% of patients the cardiac output is initially raised. Noradrenaline and adrenaline are frequently used in this clinical setting.

A vasopressor is a drug that increases the smooth muscle contraction in the walls of arterioles, thereby increasing the systemic vascular resistance. Adrenaline and noradrenaline are examples of drugs that have vasopressor action. As these drugs have a half life of just a few minutes, they are best delivered by infusion.

Noradrenaline would be the best choice in this patient because of its potent alpha action. Mix 4mg noradrenaline in 40mls dextrose 5% (1:10,000) and start an infusion via the CVP line at 5 - 10mls/hour. Adjust the rate according to the response of the blood pressure. Measures of organ perfusion such as urine output provide a more reliable end point for treatment than blood pressure alone.

The patient will need postoperative care in an ICU or high dependency area to provide closed monitoring of oxygenation, blood pressure, fluid requirements, urine output, analgesia and conscious level. Blood count and electrolytes will need rechecked. Blood gases are useful, but often not available.

In these patients surgery is lifesaving, but patients should always receive some resuscitation before they are anaesthetised to prevent rapid decompensation following induction.

### **Clinical Scenario 2**

A 69 year old man sustained a fractured femur, which was reduced and internally fixated under general anaesthetic. He has no past medical history of note, and takes no regular medication. Two days hours after the operation he complains of a dull, constant chest pain that goes down into his epigastrium. This has been present for the last few hours. A full blood count and serum electrolytes are taken, which are normal, and a chest x-ray and 12 lead ECG are organised.

Examine the following ECG:

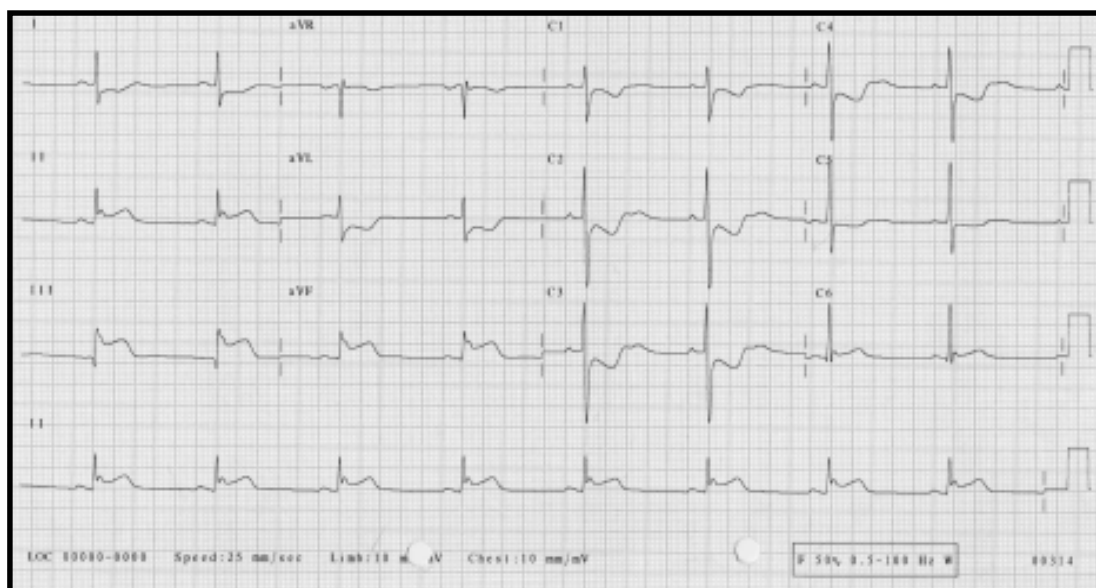

### **Question - what is the diagnosis?**

Acute inferior myocardial infarction. A diagnosis of MI requires 2

or 3 out of the following; a clear history, ECG changes or characteristic enzyme changes. The electrocardiogram (ECG) shows elevation of the ST segments in leads II, III and aVF. Causes of this finding include myocardial infarction, pericarditis and it is an occasional normal finding (chest leads V1 and V2, especially in Afro-caribbean patients).

Elevation should be 2mm or more above the baseline (1mm in the limb leads) in 2 or more leads that are looking at similar parts of the heart. Leads II, III and aVF are the leads that look at the inferior surface of the heart, and changes in these leads points to an occlusion within the right coronary artery distribution. ST elevation occurs within hours of an infarct. Over the course of days, T-wave inversion occurs, and after several months have past, these changes slowly resolve.

Myocardial cell death produces characteristic changes in the levels of several serum enzymes, which can contribute to a diagnosis of myocardial infarction. Creatinine kinase (CK) levels of greater than twice their normal level and higher than 200 mmol/litre may indicate muscle cell death, but not specifically heart muscle. They rise within 12 hours of injury. If CK is raised (normal after surgery), measurement of the cardiac specific sub-type of this enzyme (CK MB) may be helpful. CK MB levels greater than 5% of the total CK level are usually specific for myocardial cell death.

Tropinin is a muscle protein that can give the most specific indication of myocardial damage. It rises to a peak level by 12 hours post infarct, and then falls over a few days. Other enzyme levels, such as aspartate transaminase and lactate dehydrogenase rise following a myocardial infarction. They are, however much less specific, and raised levels can follow damage to other tissues such as liver and skeletal muscle.

**Question - describe the typical symptoms and signs of an MI?**

Chest pain, which is classically central and 'heavy' or 'crushing' in nature, which may radiate to the jaw, neck, arms or epigastrium. If patient has pre-existing angina, it is frequently of a similar nature, but often more severe and lasts more than 30 minutes. The patient may have nausea or be vomiting. Symptom free or 'silent' infarcts are common, especially in diabetics or the elderly.

Patients undergoing an acute myocardial infarction often appear cold, pale and sweaty. Some patients become pyrexial. They may be hyper- or hypotensive and may have a sinus tachycardia or a

dysrhythmia. Some patients will have signs of left ventricular failure, including tachypnoea and fine bibasal crackles on chest auscultation.

**Question - how would you treat this patient?**

Reassure, give high flow face mask oxygen. If possible move the patient to a coronary care unit or an intensive care unit and monitor the patient with a three lead ECG. An intravenous cannula should be sited and intravenous morphine and anti-emetic administered (if the patient is not currently receiving morphine, a slow intravenous bolus of 5-15mg is appropriate). The morphine acts as an analgesic and anxiolytic, and venodilates, reducing cardiac work.

The patient should be given 300mg of aspirin orally, and glyceryl trinitrate 0.5 mg sublingually. Thrombolysis should be considered, however in this patient's case the recent complex surgery was thought to present too great a risk of bleeding. Subcutaneous heparin (5000 units twice a day) should be given until patient is fully mobile (about day 5). The patient should be confined to bed for 24 hours, with continuous ECG monitoring, regular blood pressure measurement and daily 12-lead ECGs, serum cardiac enzyme and electrolyte assays. Smoking is a risk factor for ischaemic heart disease, and in the period following an acute myocardial infarction it can have particularly severe adverse effects, therefore it should be discouraged. The patient should be examined at least daily to check for complications.

**Complications include:**

- Arrhythmias
- Heart failure/ Cardiogenic shock
- Hypertension
- Pericarditis (Dressler's syndrome)
- Deep vein thrombosis / Pulmonary embolism
- Ventricular aneurysm / Cardiac rupture
- Papillary muscle rupture, ventricular septal defects

ACE inhibitors,  $\beta$ blockers and statins are used in some hospitals, in some patients for long term prevention of further problems. Generally, ACE inhibitors are used in patients who have had an anterior myocardial infarct who show signs of left ventricular dysfunction. Some cardiologists use  $\beta$ blockers in the immediate treatment of myocardial infarction, however most patients in the UK will receive a first dose of  $\beta$ blockers at 12 - 24 hours, provided there is no heart block, bradycardia, hypotension or heart failure.

## MULTIPLE CHOICE ANSWERS

### 1. TTTFT

Beta-blockers depress contractility and slow the heart. They were traditionally avoided in all forms of heart failure, but now, under the guidance of a cardiologist they may be useful in the treatment of some cases of heart failure. They may also precipitate asthma and should therefore be avoided in patients with a history of asthma or chronic obstructive pulmonary disease. Beta-blockers are avoided in patients with second or third degree heart block. Other side effects include fatigue, extremity coldness and glucose intolerance. Beta-blockers are a treatment for angina.

### 2. TFFFT

Normal ranges of physiological values in a 3 year old child include:

- Systolic blood pressure 80 - 100 mmHg
- Pulse rate 95 - 140
- Respiratory rate 25 - 30

Using the formula: Weight (in kg) = (Age +4) x 2

- Weight (approximately) 14 kg

The tidal volume is 5 - 7 ml per kg for all ages, and the circulating blood volume is 75 - 80 ml per kg, which gives the following values:

- Tidal volume 70 - 98 ml
- Circulating blood volume 1050 ml

### 3. FTFFT

The larynx of a child is situated at a higher level. The infant larynx is level with the third cervical vertebra compared to C6 in an adult. The epiglottis is U shaped and relatively long and the cricoid cartilage forms the narrowest part of the larynx prior to puberty. An inappropriately large tube may pass easily through the cords, and cause trauma at the level of the cricoid cartilage. The mucosa of a child is susceptible to oedema and this may result in airway obstruction after extubation. Children are prone to laryngospasm.

### 4. FTFFT

Inhalational agents that have a high degree of solubility in blood are absorbed in greater quantities during anaesthesia, and on termination of anaesthesia they are relatively slow at passing into the lung. A quantity of agent dissolved in a volume of blood will have a relatively low 'partial pressure' (when compared with agents with low solubility), and it is the 'partial pressure' that causes the agent to come out of solution in the lungs. The recovery from anaesthesia with an agent that is highly soluble in blood will therefore be slow.

In a high cardiac output state, the inhaled vapour is removed from the lungs and distributed around the body, preventing a sufficient 'partial pressure' from quickly building up. The 'partial pressure' build up in the lungs reflects the 'partial pressure' elsewhere in the body, including the brain. Induction is therefore slow.

Increasing oxygen does not affect the level of anaesthesia (unless there is a significant decrease in nitrous oxide). While trichloroethylene, methoxyflurane and ether produce good analgesia, other volatiles have little or no analgesic effects, and other analgesics are required to produce balanced anaesthesia during painful procedures. Anaesthetic effect is related to the partial pressure of the agent in the brain. At equilibrium (where the same partial pressure exists in blood and alveolar gas) the partial pressure in the brain bears a constant relationship to the partial pressure / concentration of the agent in the alveoli. The MAC or Minimum Alveolar Concentration is the concentration in the alveoli, at atmospheric pressure, that prevents movement in 50% of patients when exposed to a noxious stimulus such as skin incision. It is inversely proportional to the solubility of the drug in oil and is a measure of drug potency.

### 5. TTTFT

Stomach emptying can be slowed by many factors including trauma, anxiety, shock, hypothermia, intestinal obstruction, fatty foods, peritonitis, hypokalaemia, opioids, hyperglycaemia, anticholinergics, uraemia. Emptying may be slowed in late pregnancy

### 6. FTFTF

Cerebral blood flow (CBF) is related to the cerebral perfusion pressure.

$CPP = MAP - (ICP + CVP)$

- ICP = Intracranial Pressure
- CVP = Cerebral Venous Pressure
- CPP = Cerebral Perfusion Pressure
- MAP = Mean Arterial Pressure

An increase in intracranial pressure therefore results in a reduction in cerebral blood flow. In a person with normal intracranial haemodynamics however, the blood flow is kept constant over a wide range of blood pressures due to "autoregulation". Loss of such autoregulation is common following head injury.

#### Cerebral Autoregulation

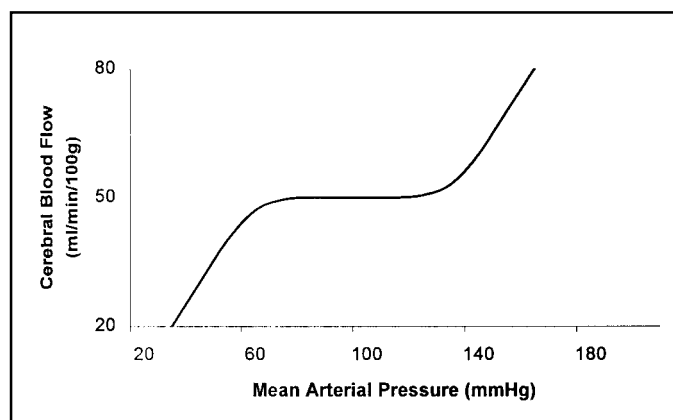

### Cerebral Response to Blood Gases

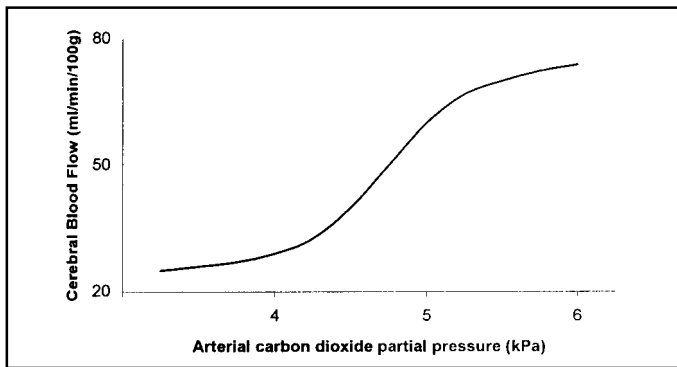

CBF is increased by:

- Ketamine
- All volatile anaesthetics (Isoflurane has the least effect)

CBF is decreased by:

- Thiopentone
- Methohexitone
- Etomidate
- Propofol

ICP rises with an increase in intracranial contents. Increased CBF secondary to vasodilatation, leads to an increase in the volume of intracranial blood and may produce a rise in ICP. Anaesthetic agents that cause a marked increase in cerebral blood flow should be avoided in patients with raised ICP.

High CO<sub>2</sub> levels increase cerebral blood flow by vasodilatation, as do arterial oxygen partial pressures below 8kPa (60mmHg).

The veins draining the head have no valves preventing back flow of blood. A head down position therefore causes an increase in intracranial venous pressure. This effect causes little more than discomfort in patients with no intracranial pathology. However even a modest rise in ICP in patients with intracranial pathology may result in reduced CBF. A similar rise in cerebral venous pressure may result from tight neck collars or neck haematomas.

### 7. TTTTT

Sympathetic stimulation leads to a collection of effects called the “fright and flight” response. This includes a number of changes that include tachycardia, increased myocardial contractility and vasoconstriction in arterioles in the skin and gut. In contrast, vessels supplying blood to skeletal muscles dilate. The blood pressure rises in response to an increase in cardiac output and an increase in systemic vascular resistance.

Sympathetic stimulation can be produced by both the sympathetic nervous system and by circulating hormones from the adrenal medulla (adrenaline and noradrenaline). The sympathetic nervous system leaves the central nervous system from thoracic and lumbar spinal levels (T<sub>1</sub> - L<sub>2</sub>, called the thoraco-lumbar outflow). When these nerves are blocked by spinal or epidural anaesthesia, the resulting vasodilatation can lead to a drop in blood pressure. If the sympathetic nerves that supply the heart (T<sub>1</sub> - T<sub>4</sub>) are blocked, both heart rate and myocardial contractility will fall, and profound hypotension can result.

The parasympathetic nervous system produces opposite effects to the sympathetic nervous system, and acts to balance the sympathetic effects.

### 8. TTTFF

Factors affecting the height of a spinal anaesthetic block include:

- Local anaesthetic dose (i.e. volume multiplied by concentration) with respect to the size of the patient
- Local anaesthetic density (baricity)
- Patient posture
- Patient factors

Volume has a relatively minor effect on spread if dose is kept constant. The level chosen for spinal injection has little effect on the height of block achieved as the injection for spinal anaesthesia can only be carried out at L<sub>2</sub>/L<sub>3</sub>, L<sub>3</sub>/L<sub>4</sub> or L<sub>4</sub>/L<sub>5</sub>. The spinal cord is present at and above L<sub>1</sub> and spinal cord damage may result from injections at or above this level, and the fused sacrum prevents injection below L<sub>5</sub>. Needle size and the direction of the bevel have little effect on the level of block.

Many patient factors can affect the eventual height of block:

- Age - older patients require smaller doses
- Height - taller patients require a larger doses
- Weight - obese patients require smaller doses
- Pregnancy - patients require smaller doses
- Kyphosis / Scoliosis may affect the spread of local anaesthetic

Factors affecting duration of a spinal anaesthetic include:

- Dose of anaesthetic given
- Local anaesthetic agent chosen
- Addition of adrenaline

### 9. TTFTF

Cardiac tamponade results from a build up of blood or other fluid in the pericardium. If this interferes with normal filling of the heart ventricles, symptoms may include tachycardia, hypotension, a high jugular venous pulsation that rises on inspiration and muffled heart sounds. The volume of the pulse falls in inspiration - “pulsus paradoxus”. If cardiac tamponade is recognised as the cause of shock it should be treated by immediate drainage.

### 10. FFFTT

All solutions of suxamethonium are destroyed by alkali, and should never be mixed with thiopentone. A small proportion of people take a long time to metabolise suxamethonium. Multiple doses also sometimes cause prolonged paralysis and in both these situations, patients may require ventilation for a few hours before muscle function returns. Suxamethonium frequently causes bradycardia, especially with a second dose in children. Some patients release high levels of potassium following suxamethonium (in particular, patients a few days following burns or spinal cord injuries, or severe muscle trauma), and this may result in serious life threatening arrhythmias or a cardiac arrest.



## VAPORISERS

Dr. Scott Simpson FANZCA, FFPMANZCA, Staff Anaesthetist, Townsville General Hospital, Queensland, Australia, Email: Scott\_Simpson@health.qld.gov.au

*This article should be read in conjunction with Volatile Anaesthetic Agents, Professor Paul Fenton (Update in Anaesthesia 2000; 11: 78-82)*

### Key to terms

SVP	Saturated vapour pressure
IPPV	Intermittent positive pressure ventilation
Anaesthetic Circuit	Anaesthetic breathing system
1.0 kPa	7.5 mmHg

## DEFINITIONS

### Vapours, Gases, and Critical temperature

A vapour is generally defined as a gaseous substance which, at room temperature and pressure, can also exist in liquid form. It condenses back to liquid relatively easily and will also evaporate easily.

The scientific distinction between a vapour and a gas is as follows. For any gaseous substance, there is a maximum temperature, the critical temperature, at which it can be compressed so as to convert it from a gas to a liquid. Once above that critical temperature, however, it cannot become liquid, no matter how much pressure is applied. It is then no longer defined as a vapour, but is defined as a gas. The critical temperature varies for different substances. For instance the critical temperature of nitrous oxide is 36.5°C. Therefore at room temperature, it is a vapour and when compressed in a cylinder, exists in the liquid and gaseous form. In a few locations in the world where anaesthesia is conducted in temperatures above its critical temperature it behaves as a gas. In contrast, oxygen is a gas in all climates, unless it is cooled below -118°C, its critical temperature. Therefore liquid oxygen supplies must be kept below this temperature (*Update in Anaesthesia 2000; 12: 6-11*)

What we call ‘volatile anaesthetics’ are liquid at room temperature and atmospheric pressure. Liquids consist of molecules which are in constant motion and have a mutual attraction to each other. If the surface of the liquid is exposed to air, or any other gas, some molecules will escape from the surface when their energy is more than the energy of the attraction to the other molecules. This is the process of evaporation which is increased with heating. Volatile agents are able to evaporate easily and do not require heating to liberate the vapour. If we pour a volatile agent into a confined space, such as a jar with a lid on it, over time the vapour liberated from the liquid accumulates in the space available in the jar. As it accumulates the molecules move randomly and exert a pressure. In the enclosed jar some of the molecules that have escaped will collide with the surface of the liquid and re-enter. Ultimately the process reaches equilibrium. At that point there are equal numbers of molecules leaving and returning to the liquid. The “saturated vapour pressure” (SVP) is the pressure exerted by the molecules in the vapour at the point of equilibrium. If the liquid is not contained in a confined space the process of evaporation continues until all of the agent has converted from liquid to vapour and dissipated into the surrounding atmosphere. Leave the lid off a bottle of halothane and there won’t be any left an hour or two later!

Table 1: Boiling points and SVP of commonly available volatile anaesthetics

Agent	Boiling point (celcius, 1atm)	Saturated vapour pressure (mmHg, 20°C)	Latent heat of vaporisation (kJ/mol)
Halothane	50.2	241	28.9
Ether	34.6	442	27.6
Enflurane	56.5	175	32.3
Isoflurane	48.5	240	-
Trichloroethylene	86.7	58	31.3
Methoxyflurane	104.7	22.5	33.9
Sevoflurane	58.5	160	-

Information collated from “Clinical Anaesthetic Pharmacology” Ed JW Dundee, RSJ Clarke, W McCaughey. Churchill Livingstone 1991.

### Saturated Vapour Pressure (SVP)

As explained above, the SVP is defined as the pressure exerted by the vapour in equilibrium with the liquid phase. It is dependent on the agent concerned, and its temperature, nothing else. When SVP is equal to atmospheric pressure, the liquid boils, i.e pure water at sea level at 100°C has an SVP = 760mmHg (101.3kPa).

### Latent heat of vaporisation

Energy is needed to convert a substance from a liquid state into vapour or gas. The latent heat of vaporisation is defined as the amount of energy required to convert 1g of liquid into vapour without a change in temperature. The more volatile the liquid is, the less energy required. The latent heat of vaporisation is expressed as kJ/g, or kJ/mol, considering different agents have different molecular weights. If the energy is not supplied from an external source then it must be taken from within the liquid itself. This causes the liquid to cool (heat energy is used). Drop some halothane or ether on your forearm and feel it cool as it evaporates, taking heat from your skin.

### Volatility

This is the common term which links latent heat of vaporisation and saturated vapour pressure. The more 'volatile' an agent, the less energy required to convert liquid into vapour, and the more pressure exerted by that vapour at a given temperature. It is agent and temperature dependent. Trichloroethylene, for instance, is less volatile than ether.

### Examples of points made so far:

Take the lid off a tin of paint and you will smell its vapour. The smell is strong at first, because the vapour is concentrated in the tin. It is in equilibrium with the paint. We say it is 'saturated'. The tin has been closed for a long time, and the saturated vapour pressure is the point where equal numbers of paint molecules are becoming vapour, or returning into the liquid (paint). Very soon after removing the lid the smell disappears. The vapour has diffused away in the atmosphere, and because the paint is poorly volatile, very little is liberated from the paint. If left open, the paint becomes solid before it evaporates.

Compare this with petrol, which is more volatile. If the lid is left off the tin the smell continues to be strong as large amounts of vapour are being released from the petrol. Within a short time there is no petrol left in the tin, it has all become vapour and dispersed into the atmosphere. If the petrol can was filled on a mild day, on a hotter day the tin will hiss out as you open the lid, and on a colder day the tin sucks air in. The SVP is higher on hot days, and lower on cold days, because it is dependent on temperature.

### VAPORISERS

Vaporisers are devices designed to deliver safe concentrations of volatile anaesthetic vapour to patients' breathing circuits. The volatile agent goes in to the vaporiser in liquid form, and amazingly comes out as a vapour, at precisely the concentration desired by the anaesthetist! There are features common to most vaporisers, such as the variable bypass channel, and the vaporising chamber, but most vaporisers are agent specific, meaning their dimensions are based on the characteristics of one volatile agent, and they only perform reliably if used with that agent.

### VAPORISER CLASSIFICATION SYSTEMS

Most classification systems are academic or cumbersome, and have reducing clinical relevance the more comprehensive they become. In practical terms it is important to be able to discriminate

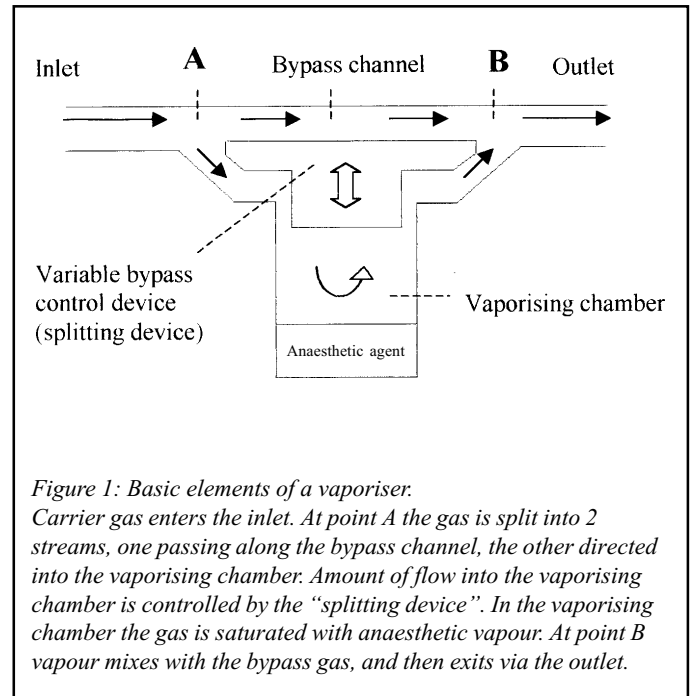

Figure 1: Basic elements of a vaporiser.

Carrier gas enters the inlet. At point A the gas is split into 2 streams, one passing along the bypass channel, the other directed into the vaporising chamber. Amount of flow into the vaporising chamber is controlled by the "splitting device". In the vaporising chamber the gas is saturated with anaesthetic vapour. At point B vapour mixes with the bypass gas, and then exits via the outlet.

between different characteristics that dictate how they are used, or how they may be expected to perform. Develop your own system. In terms of practicalities, the following distinctions can be made:

- **Drawover v plenum.** Drawover is when carrier gas is pulled through the vaporiser by a decrease in downstream pressure, and plenum is when carrier gas is pushed through the vaporiser at higher than ambient pressure.
- **Agent specific v multi-agent.** Determines what agent can be used in them, or should go in them!
- **Temperature compensated?** Indicates a consistency of performance with time, over a range of operating temperatures, versus a need to adjust dial settings according to decreasing output as vapour cools as it evaporates
- **Flow stabilised?** At what flow rates will the output be reliable?
- **Flow resistance?** How much effort is required to draw, or push, carrier gas through the vaporiser?

Combining some of the above characteristics vaporisers can broadly be classified into 2 main categories, as follows

1. Drawover or Plenum
2. Calibrated or Uncalibrated

Calibration is the term used to describe the precision of performance within a specified range of conditions. Manufacturers can supply data to show how well output matches ideal performance. Giving a hypothetical example a vaporiser may be calibrated to perform within  $\pm 10\%$  of the dial setting, at flow rates between 2

and 10 litres per minute. Outside these limits the performance is less reliable. The structural methods used to improve calibration are those outlined below.

**VAPORISER STRUCTURE**

The basic components are the vapour chamber and the flow-splitting device. In all situations other than open-drop anaesthesia the vapour needs to be delivered to the patient in a carrier gas passing along a circuit. Volatile agents cannot just be poured in because their SVP is too high, and the final concentration would be too great, causing overdose. The vaporiser is used to add a safe, predictable and controlled concentration, a small percentage, into the anaesthetic circuit.

Most vaporisers use the method of “splitting” the carrier gas into two streams as it passes through. One stream passes into the vaporising chamber, and the other passes by (by-passes) directly into the anaesthetic circuit without contacting the vapour. The ratio of the gas flows in each stream is called the “splitting ratio”. The splitting ratio is principally controlled by the concentration dial, allowing the anaesthetist to vary the output according to the desired amount.

The exception to all of the above is the “copper kettle” which is a ‘measured flow’ vaporiser, as opposed to ‘variable bypass’. It will not be considered further, here.

Downstream of the vaporiser the streams of vapour-laden, and vapour-free gas mix in the anaesthetic circuit. In calibrating the vaporiser, the manufacturer assumes that all carrier gas passing through the vaporising chamber becomes saturated with anaesthetic vapour, which has a known concentration. The desired output can then be produced by altering the splitting ratio which alters the dilution of the vapour laden gas with fresh gas to give a final concentration in the clinical range. It is vital therefore that the vaporising chamber produces a saturated vapour. This is achieved by the following devices.

- Wicks are used to increase surface area of the liquid/gas interface where vaporisation is occurring, ensuring saturation of carrier gas as it passes through. This is crucial to the determination of output. Without wicks the vapour concentration will not achieve

SVP, because too little vapour can be liberated from the small interface in unit time as the carrier gas passes through (taking vapour away). Performance will fall with time. One example of a wick-less vaporiser is the Goldman.

- Baffles are simple plates or channels that encouraging mixing of carrier gas with vapour, ensuring saturation before the carrier gas returns to the anaesthetic circuit.
- Temperature compensation devices. Since SVP is dependent on temperature, the output of the vaporiser will be different at different temperatures if the splitting ratio remains fixed. As temperature falls the SVP falls, so the concentration leaving the vaporising chamber will fall and thus contribute less vapour to the carrier gas as it passes through, and the final output (%) will fall, unless the splitting ratio alters to accommodate the change. This is exactly what the manufacturers have introduced, and called “temperature compensation”. There are various designs which achieve this, but the common element is an indirect increase in the splitting ratio with a fall in temperature, without any alteration of the dial setting, by outflow modification. (see below)

The aim of the calibrated vaporiser is the provision of a steady, predictable output that correlates with the dial setting in a wide range of environmental conditions.

To offset the cooling effect of vaporisation (latent heat) vaporisers are built from conductive materials which can donate heat energy to the liquid. A large mass of such material is referred to as a “heat sink”. Examples include the water bath of the EMO, and the thick copper base of the Tec vaporisers. Improvised heat-sinks can be made, such as wrapping a warm, wet towel around a Boyle’s bottle when using ether.

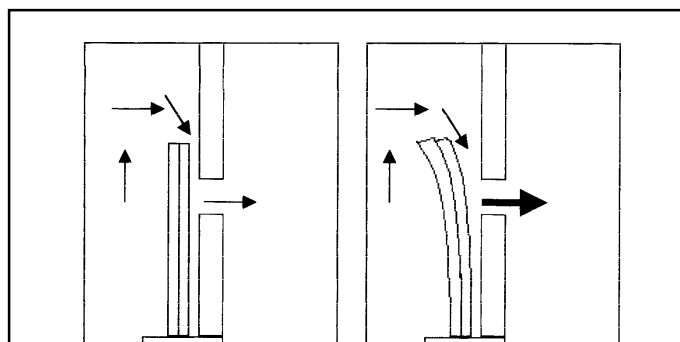

Figure 2a. Bimetallic strips  
The two metals expand or contract in response to temperature, but at different rates such that the strip is forced to bend away from the aperture when the system cools, allowing more vapour out, and compensating for the decrease in vaporisation at the lower temperature.

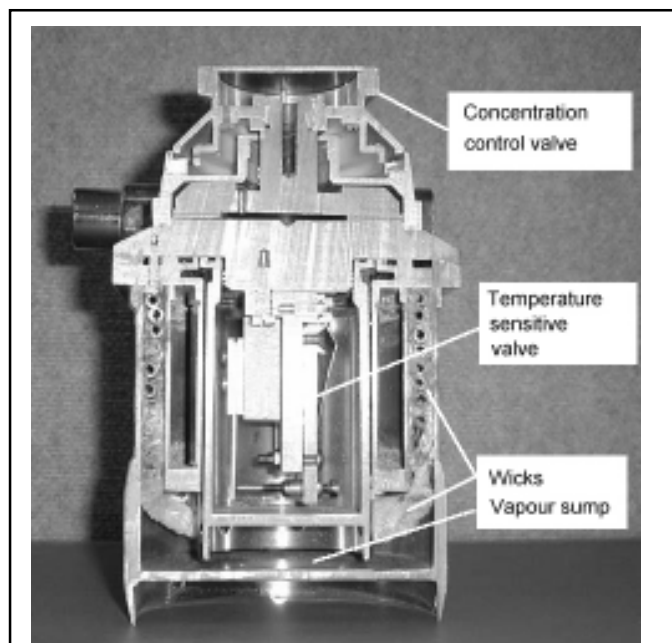

Figure 2b: Cut-away view of a Fluotec2 halothane vaporiser (Cyprane, UK) Note the solid metal structure which acts as a heat sink and the wicks to aid vaporisation. Note the complex internal construction of the temperature compensation valve which causes high internal resistance in contrast to the EMO (figure 3a). This vaporiser cannot be used in a drawover mode.

Further temperature compensation (flow compensation) occurs by internal adjustments in the splitting ratio when temperature falls or rises. The commonest method for achieving this is with a bimetallic strip (Tec series) in which two conjoined, dissimilar metals expand or contract at different rates as temperature varies, thus opening or closing the output aperture of the vapour chamber. An alternative system is the ether-filled-bellows (Penlon) attached to a spindle valve. The bellows change size with temperature changes, altering the relationship of the spindle to the seat, with an effect on the output, and therefore the splitting ratio. As vapour cools the bellows shrink, and the aperture increases, allowing a greater 'output'.

### DRAWOVER VAPORISERS

The distinction between operational needs of draw-over and plenum anaesthesia will be covered in a subsequent article.

The basic elements are:

- Low internal resistance to gas flow
- Gas is drawn through the vaporiser into the anaesthetic circuit only in inspiration, or by the use of a self inflating bag or bellows, therefore flow is not constant (peak inspiratory flow rates 30-60l/min), but 'pulsatile'.
- Do not require a pressurised gas supply

**Goldman halothane vaporiser** (similar to McKesson and Rowbotham -Trilene) Adapted from Leyland fuel pump. Very simple splitting device. No temperature compensation - therefore output varies with temperature, and decreases during use as the temperature falls. With halothane the maximum output is 3% because of the small vapour chamber and absence of wicks. It can be used in a circle system, but needs vigilance as the output varies dramatically depending on whether the patient is spontaneously breathing (lower), or ventilated by positive pressure (higher). Circle flow rates also influence output. This area is too complex to tackle within this broad article.



Figure 3a: The EMO ether vaporiser. Note the mass of water providing the heat sink, and the temperature compensation device - an ether filled bellows

### Oxford Miniature Vaporiser (OMV) (drawover or plenum).

- Portable
- Multi-agent
- Easily cleaned and serviced
- Wire-gauze wick
- No temperature compensation
- Small heat sink containing glycol

### EMO ether inhaler (Epstein, Macintosh, Oxford)

- Robust
- Water-bath heat sink
- Ether bellows temperature compensator
- Level indicator

**Open drop techniques** (ether and chloroform) - e.g. Schimmelbusch mask and Ogston's inhaler

- Drop rate gives inspired concentration
- Number of layers of gauze or lint important (wick)
- Freezing may occur (latent heat)
- Eye protection needs to be considered (freezing)

### PLENUM VAPORISERS

Plenum is a term derived from Latin, and means "full". It is the opposite to vacuum. In air conditioning terminology it applies to air that is forced in, cleaned and temperature adjusted. Plenum vaporisers are designed for use with continuous flow of pressurised gas, and have high internal resistance. Modern versions are universally agent specific, and referred to as "flow stabilised"; i.e. perform equally well over a large range of fresh gas flow (FGF) ( $\pm 20\%$  accurate 0.5-10 l/min).

**Boyle's bottle.** Not temperature compensated, nor agent specific although designed for use with ether. The cowling over the U-tube forces gas to bubble through ether when down, increasing output by increasing the gas/liquid interface. There is the potential for a surge of high concentration of ether when first turned on, as the chamber contains ether at SVP (equilibrated while standing idle SVP is 60kPa -  $(60/101.3) \times 100 = 59.2\%$  or 450 mmHg -  $(450/760) \times 100 = 59.2\%$ ). Cools dramatically in use with a drastic decrease

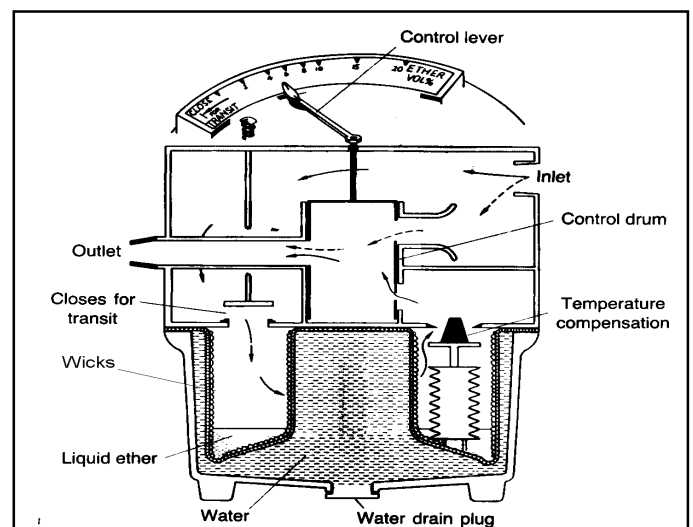

Figure 3b: EMO ether vaporiser, Oxford inflating bellows and breathing system

in output, and the possibility of the patient lightening or awakening unless counteracted by an external heat sink (hot towel, or warm water bath) and further depression of the cowling into the ether liquid. May need frequent refilling while in use.

### **Tec 2 (Ohmeda) Halothane vaporiser**

- Temperature compensated
- Bimetallic strip
- Series of wicks
- Metal heat sink

Many newer models of vaporisers exist and have refined performances, particularly for low flow rates to facilitate low flow circle anaesthesia. They are characterised by larger wicks, output resistance to minimise the 'pumping effect' and metal heat sinks

### **PUMPING EFFECT (INCREASED VAPOUR OUTPUT AT LOW FLOWS)**

This effect applies to plenum vaporisers especially at low flow rates with IPPV when back pressure is exerted on the vaporiser. Typically this happens when manually assisted or ventilator controlled ventilation is being used.

The pressure in the anaesthetic circuit and vapour chamber rises during inspiration. This drives some saturated vapour back from the vapour chamber into the inlet path, which spills into the bypass carrier gas when the pressure falls during expiration. The by-pass is thus contaminated and will result in an inaccurate output concentration. Designers have minimized the effect by increasing the internal resistance which reduces the back flow into the vaporising chamber. Other measures to prevent it include an outlet 'non-return valve' (resistance) which maintains constant pressure in the vapour chamber, and long high-resistance inlet pathways. (Drager)

### **PRESSURE EFFECT (DECREASED VAPOUR OUTPUT AT HIGH FLOWS)**

Applies to plenum vaporisers at high flow rates during IPPV and is of minor significance. Positive pressure compresses the carrier gas, thus concentrating it. When the pressure is released (expiration), volume increases, the gas density falls and the vapour concentration also falls.

### **VAPORISER SAFETY**

To enhance the safety aspects of using volatile agents the following adaptations have become commonplace:

- Keyed filling devices reducing the likelihood of filling with the wrong agent
- Agent level indicators
- Stable mounting brackets to prevent tipping and spillage
- Correct placement in circuit:
- Plenum Downstream from rotameters, upstream of oxygen
- Draw-over Upstream from self inflating bag/bellows
- Interlock devices to stop the concurrent use of two vaporisers in series, preventing contamination from upstream to downstream vaporiser. If an interlock device is fitted, a small

metal rod protrudes from the side of the vaporiser, towards the rear. When the dial is turned on, the rod sticks out further. If two interlock compatible vaporisers are mounted side by side then this prevents the second vaporiser from being switched on as the rods are in contact, and the second dial will not turn.

- Correct placement in series (if no interlock): More volatile agents (highest SVP) placed downstream as less volatile agents have lower splitting ratios and will create less contamination of downstream vaporisers if both are switched on. Halothane downstream to prevent thymol contamination of others
- Agent monitoring, checking that the circuit concentrations are adequate

### **Potential misadventures**

- Overfilling may have an unpredictable effect on output. Liquid agent may spill into the bypass and increase output dramatically, or conversely, reduced wick surface area may lead to reduced output. If overfilled it is wise to drain the vaporiser to the recommended range as indicated by the agent indicator.
- Crossed connection-reversed connection. Will lead to unpredictable output. In the Tec series the manufacturers claim this to be approximately double what is dialled. Not recommended!
- Tipped over. High output as the splitting device inlet is contaminated by liquid agent and bypass gas also collects vapour. Needs to be flushed for 10 mins at 10 litres/min before use, or left to stand overnight.
- Incorrect filling (wrong agent). Output will not match dial setting, and may be grossly excessive (overdose), or inadequate (intraoperative awareness) if used by an unsuspecting anaesthetist

### **Hypobaric and Hyperbaric environments**

In these situations the output from the vaporiser can alter. SVP remains unchanged as it is only temperature dependent, but there is a change in ambient pressure relative to SVP. This then alters the output concentration (%). However the partial pressure of the vapour does not change. Since the partial pressure of the volatile agent is the important factor in causing anaesthesia, there is no reason to vary the vaporiser settings from normobaric use. If using agent monitoring, however, the MAC value in % will be inappropriate and should not be relied upon. Use mmHg or kPa as a guide instead. Pressure reversal of anaesthesia is not a clinically significant phenomenon in commonly used therapeutic hyperbaric chamber pressures.

### **Final words**

It is impossible to cover all aspects of vaporiser function and performance, in all conditions, with all agents. Hopefully an understanding of the general principles involved will allow you to predict what is safe, unsafe, achievable, or impossible when confronted with clinical choices, or a need to modify the use of a vaporiser to suit your own particular needs.

## OBSTETRIC ANAESTHESIA - PLACENTAL ABRUPTION

Dr Anne Sophie Ducloy, Maternite Jeanne de Flandre, CHRU, Avenue O'Lambret, 59037, Lille, Cedex, France  
Dr Juliette Lee, Plymouth, UK

Placental abruption is defined as separation of the placenta from the decidua basalis before delivery of the fetus. Bleeding occurs from the exposed decidual vessels, and may be extensive. However, because haemorrhage is often occult - with blood collecting around the placenta and fetus or in the myometrium and broad ligaments, the amount of blood lost is easily underestimated.

Fetal distress occurs because of loss of area for maternal-fetal gas exchange. Abruption is an important cause of intrauterine growth retardation, premature labour and fetal death.

### Incidence of placental abruption

In a large retrospective study in Sweden on 894,619 births, the incidence was estimated at 0.5% of all pregnancies, with a perinatal mortality of 20%.

The cause of abruption is not known, but several factors are known to be associated which include:

- Trauma
- Chronic hypertension
- Premature rupture of the membranes
- Pre-eclampsia and eclampsia
- History of previous abruption (the risk is increased ten times).
- Advanced maternal age and parity
- Cocaine use
- Smoking
- Black ethnic origin
- Some uterine and fetal malformations
- Thrombophilia

### Clinical Presentation

Placental abruption usually arises unexpectedly. Classically it presents with vaginal bleeding, severe, intense abdominal pain, uterine contractions, and intrauterine death of the fetus. Proteinuria and hypertension may occur but may be a secondary manifestation. There may be haemorrhagic shock if there is a large retroplacental haematoma - when the uterus may contain more than 1500mls of blood. The amount of vaginal bleeding may be very much less than the true blood loss. This classical presentation is present in less than one third of cases, and placental abruption can therefore present as a threat of premature delivery or acute fetal distress or an unexplained fetal death. In Lille our experience of 102 placental abruptions out of 18,082 deliveries in 4 years (0,56%), only 19 presented with classical clinical symptoms. 45 were diagnosed by examination of the placenta and 36 were suspected before or during delivery, either during Caesarean section for fetal distress or premature labor associated with vaginal bleeding.

Placental abruption can be difficult to diagnose especially if associated with a placenta praevia and can complicate this diagnosis in 4% of cases. Ultrasound examination often shows

the presence of a retroplacental haematoma, but a normal ultrasound does not exclude the diagnosis.

Abruption may be missed because the clinical signs are hidden by the onset of labour associated with a hyperkinetic and hypertonic uterus. Epidural analgesia for labour may also obscure the symptoms. The diagnosis is sometimes made by examination of the placenta after a normal vaginal delivery or at caesarean section when a haematoma may be found. Alternatively, severe cases with fetal death and disseminated intravascular coagulation (DIC) have been described in which the presentation was a failure to progress in labour.

### Classification of abruption

Taking into account the differences in clinical presentation, two classifications are suggested. The classification by Page has four stages;

**Stage 0:** a diagnosis purely on pathology without symptoms.

**Stage 1:** quiescent form with a live baby.

**Stage 2:** mild form with onset of clotting problems.

**Stage 3:** severe form with coagulation defects and fetal death in utero.

### Sher's classification has 3 stages:

**Stage I** is mild with unexplained vaginal bleeding and a retrospective diagnosis of a small haematoma post-partum.

**Stage II** is the intermediate form with a hypertonic uterus and a live baby.

**Stage III** is the severe form with an intrauterine death, subdivided into IIIA without coagulopathy and stage IIIB with coagulopathy.

### Are there any warning signs of a placental abruption?

No symptoms predictive of placental abruption have been found. However elevation of fibrin and fibrinogen degradation products (FDPs) in the last few days prior to abruption have been detected. D-dimers (the products of the degradation of stabilised fibrin), have been shown to be significantly elevated in patients who subsequently suffer an abruption between 32 and 40 weeks.

A persistent increase in the fetal heart rate has also been associated with subsequent abruption. In addition two other parameters have been shown to be present in 60% of cases in the weeks before the event: lowering of the maternal plasma volume (which appears as an increase in haematocrit) and the presence of a notch on the uterine artery Doppler curve. However in 30% of cases neither of these abnormalities are found and so their value as predictors of abruption are limited.

### Complications of Abruption

The major complications are:

- Haemorrhagic shock
- Disseminated intravascular coagulation (DIC)

- Acute renal failure
- Fetal distress
- Premature labour
- Intrauterine fetal death

Coagulopathy occurs in 10% of cases of abruption and is more common where there is fetal distress or fetal death. Abruption is the most common cause of haemorrhagic DIC in pregnancy.

Fetal distress due to hypoxia is a major risk. Maternal hypovolaemia due to a large retroplacental bleed, causes maternal hypotension, reduced uterine blood flow and a reduction in maternal blood oxygen carrying capacity. Abruption also causes a reduction in the surface area of the placenta available for oxygen exchange. Fetal anaemia may also occur if there is blood loss from the fetal side of the uteroplacental circulation. Up to 25% of perinatal deaths are due to abruption.

Premature labour is a frequent result of placental abruption. A cycle may be established whereby a small abruption stimulates uterine contractions which cause further separation of the placenta. Preterm delivery results in significant neonatal morbidity and mortality. As many as 50% of these babies have respiratory distress syndrome. Where there are no signs of fetal distress, it is sometimes possible to inhibit uterine contractions to allow further fetal maturation. However the advantages of this must be balanced against the risks of giving tocolytic drugs and of intrauterine fetal death.

#### **Anaesthetic management of placental abruption**

Delivery of the fetus and placenta is the definitive treatment. However if the degree of abruption is minor, and there is no fetal or maternal compromise, the pregnancy may be allowed to continue, to allow fetal lung maturation.

If the diagnosis of a significant abruption is suspected, 2 large bore intravenous cannulae should be sited and blood taken for crossmatching and for measurement of haemoglobin, haematocrit and coagulation screen. The mother should be given oxygen, a left lateral tilt should be ensured and there should be regular monitoring of blood pressure, heart rate and urine output. The fetal heart rate should be monitored and where available a fetal scalp electrode should be placed.

Most cases however will require prompt delivery, and the preferred route of delivery depends on several factors.

- Vaginal delivery is recommended when the fetus is dead. This avoids the risks of caesarean section in a patient who may be hypovolaemic and coagulopathic. It may also be chosen where there is no fetal distress and the cervix is favourable. Epidural analgesia may be provided for these patients when clotting studies are normal, and there is no evidence of hypovolaemia.
- Some studies have shown an increase in survival rate when the baby is delivered by caesarean section, and this is the most common mode of delivery where there is acute fetal distress. General anaesthesia is preferred for most of these cases and management of haemorrhage and associated hypovolaemia together with coagulopathy is critical.

Aggressive volume resuscitation is required with crystalloid or colloid, being guided by heart rate, blood pressure and urine output. Central venous pressure monitoring is also often helpful in managing severe haemorrhage. A line can be placed via an antecubital or an internal jugular vein (sites which can be compressed if there is haemorrhage from accidental arterial puncture) if the clotting is abnormal. Transfusion of cross-matched blood is necessary to keep the haemoglobin above 7g/dl.

- Coagulopathy should be corrected, ideally guided by clotting studies where these are available. The coagulopathy is most frequently due to disseminated intravascular coagulation with fibrinolysis predominating. However where large volumes of fluids and/or blood have been transfused, there may also be a dilutional element to it.

- The object during caesarean or vaginal delivery is to try to make the blood coagulate at the moment of delivery. This can be done by various methods and no one has proved to be superior than the others: infusion of 20ml/kg of fresh frozen plasma, the infusion of 0.1g/kg of fibrinogen or the use of antifibrinolytic agents, particularly aprotinin, which is a plasmin inhibitor but also retains anticoagulant properties. Aprotinin may be given as up to 500,000 kallikrein units immediately by slow intravenous injection, followed by 200,000 units every hour by continuous intravenous infusion until haemorrhage is controlled. In the presence of DIC up to 1,000,000 units or more may be necessary.

Persistent haemorrhage after delivery may be due to the coagulopathy. However it may also be due to failure of the uterus to contract down once it is empty, which occurs more commonly in these patients. An oxytocin infusion should be commenced after delivery (20-40 units in 500mls of saline over 4 hours). Persistent uterine atony requires administration of other drugs such as ergometrine and 15methyl PGF<sub>2</sub> alpha (Hemabate).

#### **Conclusion**

Placental abruption is a complication of 0.25 - 1% of all pregnancies and occurs in 4% of those with severe pre-eclampsia. It occurs suddenly and is often unexpected. Its clinical presentation may be mistaken for isolated vaginal bleeding, fetal distress or labour with a hypertonic, hyperkinetic uterus.

The apparent blood loss may greatly underestimate the true amount of haemorrhage which is usually due to a retroplacental haematoma. Disseminated intravascular coagulation may also be present.

Caesarian section may reduce the risk of perinatal mortality in the case of placental abruption with a live baby but vaginal delivery is recommended if the baby is dead. General anaesthesia is usually required because of the frequent presence of maternal hypovolaemia due to haemorrhage, the presence of a coagulopathy, and the potential for further intra-operative bleeding.

#### **Further Reading**

1. Chestnut D.H. Obstetric Anaesthesia – Principles and Practice, Chapter 37: Antepartum and Postpartum Haemorrhage. Mosby 1994.
2. Chamberlain C, Steer P. ABC of labour care: obstetric emergencies. British Medical Journal 1999;318:1342-5.

**Some useful Web Addresses**

<a href="http://www.nda.ox.ac.uk/wfsa">http://www.nda.ox.ac.uk/wfsa</a>	Update in Anaesthesia /World Anaesthesia / WFSA
<a href="http://www.ua.arh.ru">http://www.ua.arh.ru</a>	Update in Anaesthesia - Russian
<a href="http://www.sfar.org/update/updatechapo.html">http://www.sfar.org/update/updatechapo.html</a>	Update in Anaesthesia - French
<a href="http://www.aagbi.org/">http://www.aagbi.org/</a>	Association of Anaesthetists of Great Britain and Ireland
<a href="http://www.anzca.edu.au/">http://www.anzca.edu.au/</a>	Australian and New Zealand College of Anaesthetists
<a href="http://www.asahq.org/homepageie.html">http://www.asahq.org/homepageie.html</a>	American Society of Anesthesiologists
<a href="http://www.rcoa.ac.uk/">http://www.rcoa.ac.uk/</a>	Royal College of Anaesthetists of UK
<a href="http://www.aaic.net.au/">http://www.aaic.net.au/</a>	Anaesthesia & Intensive Care
<a href="http://www.anesthesiology.org/">http://www.anesthesiology.org/</a>	Anesthesiology
<a href="http://www.anesthesia-analgesia.org/">http://www.anesthesia-analgesia.org/</a>	Anesthesia and Analgesia
<a href="http://www.bja.oupjournals.org/">http://www.bja.oupjournals.org/</a>	British Journal of Anaesthesia
<a href="http://www.cja-jca.org">http://www.cja-jca.org</a>	Canadian Journal of Anaesthesia
<a href="http://www.bmj.com/">http://www.bmj.com/</a>	British Medical Journal
<a href="http://www.thelancet.com/">http://www.thelancet.com/</a>	The Lancet
<a href="http://www.nejm.org">http://www.nejm.org</a>	New England Journal of Medicine
<a href="http://www.esraeurope.org/">http://www.esraeurope.org/</a>	European Society of Regional Anaesthesia
<a href="http://www.scata.org.uk/">http://www.scata.org.uk/</a>	Society of Computing and Technology in Anaesthesia
<a href="http://www.pedsanesthesia.org/">http://www.pedsanesthesia.org/</a>	Society for Pediatric Anesthesia
<a href="http://www.histansoc.org.uk/">http://www.histansoc.org.uk/</a>	History of Anaesthesia Society
<a href="http://www.vasgbi.com/">http://www.vasgbi.com/</a>	Vascular Anaesthesia Society of Great Britain and Ireland
<a href="http://www.oaa-anaes.ac.uk/">http://www.oaa-anaes.ac.uk/</a>	Obstetric Anaesthetists Association
<a href="http://www.cochrane.org/">http://www.cochrane.org/</a>	Cochrane Collaboration
<a href="http://www.virtual-anaesthesia-textbook.com/">http://www.virtual-anaesthesia-textbook.com/</a>	Virtual Anaesthesia Textbook
<a href="http://www.frca.co.uk">http://www.frca.co.uk</a>	Self assessment for anaesthesia exams
<a href="http://www.eguidelines.co.uk/">http://www.eguidelines.co.uk/</a>	eGuidelines
<a href="http://www.ncbi.nlm.nih.gov/PubMed/">http://www.ncbi.nlm.nih.gov/PubMed/</a>	PubMed
<a href="http://www.ohsu.edu/clinweb/">http://www.ohsu.edu/clinweb/</a>	Cliniweb
<a href="http://www.medexplorer.com/">http://www.medexplorer.com/</a>	MedExplorer
<a href="http://www.medimatch.com">http://www.medimatch.com</a>	MediMatch
<a href="http://www.anest.ufl.edu/vam">http://www.anest.ufl.edu/vam</a>	Animation of gas flows in an anaesthesia machine

**Dear Reader**

If you would like to receive **Update in Anaesthesia** please write to: Dr C Collins, Secretary, World Anaesthesia, Royal Devon and Exeter Hospital (Wonford), Exeter EX2 5DW, UK. The fax number is +44 1392 402472. Alternatively contact the editor by email - [iain.wilson5@virgin.net](mailto:iain.wilson5@virgin.net) When writing please include your name, address, email (if available), your title and role, and a few details about your hospital and work. If you would like extra copies of Update to distribute to other anaesthetists, please let us know how many you require, and the names of the readers.

---

*Sponsored by:* World Federation of Societies of Anaesthesiologists, Level 8, Imperial House, 15-19 Kingsway, London WC2B 6TH, United Kingdom. Tel: 020 7836 5652. Fax: 020 7836 5616. E-mail: [wfsa@compuserve.com](mailto:wfsa@compuserve.com)

*Typeset by:* Angela Frost

*Printed in Great Britain by:* Media Publishing

*Correspondence to editor:* Dr I H Wilson, Anaesthetics Department, Royal Devon & Exeter Healthcare NHS Trust, Barrack Road, Exeter, EX2 5DW, UK. E-mail: [iain.wilson5@virgin.net](mailto:iain.wilson5@virgin.net)

**Disclaimer**

World Anaesthesia takes all reasonable care to ensure that the information contained in Update is accurate. We cannot be held responsible for any errors or omissions and take no responsibility for the consequences of error or for any loss or damage which may arise from reliance on information contained.